

# Understanding Antennas for the Non-Technical Ham

A Book By Jim Abercrombie, N4JA  
(Jim Abercrombie [n4ja@prtcnet.com](mailto:n4ja@prtcnet.com))

Illustrations by Frank Wamsley, K4EFW

Edited by Judy Haynes, KC4NOR

Copyright July 2005. Second Edition

This is a book length web article provided by the author FREE for all hams.

---

**Note:** This is copyrighted material and is the property of Hamuniverse.com and/or the article author and is to be used only for personal non-profit educational use.

---

Hamuniverse.com is Powered by Ham Radio!

© 2000 - 2008 N4UJW Hamuniverse.com or article author! - All Rights Reserved.

# ***Preface***

One reason for writing this book is to educate you so you can make an informed choice concerning the best antenna for you. Another reason is to dispel the many antenna myths that circulate in the amateur community. The third reason is a desire to teach basic antenna theory to the average ham. Therefore, to achieve that goal, you should read this book from cover to cover. It was written primarily for the newcomer and the non-technical old-timer.

This book is about common medium wave and high frequency (short wave) antennas, but the theory presented here relates to antennas of any frequency. It is in a condensed form and the antenna theory is explained so most hams can understand it. Realizing many hams are mathematically challenged, only simple mathematics procedures are used. If you can add, subtract, and divide using a calculator, you will not have trouble with this book.

A few principles in here are based on conclusions drawn from the Laws of Physics. Everything else in this book can be found scattered through The *A.R.R.L. Antenna Book* and nothing in here contradicts what is written there.

# Understanding Antennas for the Non-Technical Ham

## *Contents*

<b>1.</b>	<b>Why All The Fuss About Antennas</b> .....	<b>1</b>
<b>2.</b>	<b>How Antennas Work</b> .....	<b>3</b>
<b>3.</b>	<b>Polarization Of Electromagnetic Waves</b> .....	<b>5</b>
<b>4.</b>	<b>Frequency</b> .....	<b>6</b>
<b>5.</b>	<b>The Ionosphere and Modes of HF Propagation</b> .....	<b>7</b>
5.1	The Ionosphere .....	7
5.2	Ground-Wave Propagation .....	8
5.3	Direct Wave or Line of Sight Propagation .....	8
5.4	Propagation by Refraction .....	9
5.5	Skywave Propagation .....	9
5.6	Greyline Propagation .....	10
5.7	Long Path Propagation .....	10
5.8	160-Meter Propagation .....	11
5.9	80-Meter Propagation .....	11
5.10	40-Meter Propagation .....	11
5.11	30-Meter Propagation .....	12
5.12	20-Meter Propagation .....	12
5.13	17-Meter Propagation .....	12
5.14	15-Meter Propagation .....	12
5.15	12-Meter Propagation .....	12
5.16	10-Meter Propagation .....	13
<b>6.</b>	<b>Standing Wave Ratio</b> .....	<b>14</b>
<b>7.</b>	<b>Real Antenna Systems</b> .....	<b>16</b>
<b>8.</b>	<b>Half-Wave Resonant Dipole Antennas</b> .....	<b>17</b>
8.1	The Half-Wave Flat-Top Dipole .....	17
8.2	Inverted-V Dipole .....	18
8.3	Dipole Shape Variations .....	20

8.4 Calculating the Length of a Half-Wave Resonant Dipole ..... 20

8.5 The Decibel ..... 21

**9. Antenna Basics ..... 22**

9.1 Resistances and Reactance ..... 22

9.2 Feeding Dipoles Efficiently ..... 23

9.3 The Cause of Feed-Line Radiation ..... 25

9.4 Baluns ..... 26

**10. Other Types of Dipoles ..... 27**

10.1 A Shortened Dipole Using Loading Coils ..... 27

10.2 All Band Dipole ..... 28

10.3 The Sloping Dipole ..... 28

10.4 Half-Wave Resonant Sloping Dipole ..... 28

10.5 The Folded Dipole ..... 29

10.6 The Double Bazooka Dipole ..... 30

10.7 Broad-Banded Coax-Fed Fan Dipole ..... 31

10.8 Two-Element Collinear Dipole ..... 31

10.9 4-Element Collinear Dipole ..... 32

10.10 Coax-Fed Dipoles Operated on Odd Harmonic Frequencies ..... 33

10.11 All Band Random Length Dipole ..... 35

10.12 All Band Center-Fed Random Length Dipole ..... 35

10.13 A 2-Band Fan Dipole ..... 35

10.14 Trapped Dipole for 75 and 40 Meters ..... 36

10.15 The Extended Double Zepp Dipole ..... 37

10.16 The G5RV Dipole ..... 37

10.17 Off-Center Fed Dipoles ..... 39

**11. End-Fed Antennas ..... 42**

11.1 End-Fed Zepp ..... 42

11.2 End-Fed Random Length Antenna ..... 42

**12. The Half Sloper ..... 44**

**13. Vertical Antennas ..... 46**

13.1 Why Verticals Are Used ..... 46

13.2 Disadvantages of Using Quarter-Wave Verticals ..... 47

13.3 Long and Short Verticals ..... 48

13.4 Unscientific Observations of Verticals ..... 49

13.5 The Inverted-L Vertical ..... 50

13.6 Vertical Mobile Antennas ..... 51

**14. One-Wavelength Single Loop Antennas ..... 54**

14.1 The Horizontally Oriented Loop ..... 54

14.2 The Vertically Oriented Single Loop for 40 and 80 Meters ..... 56

**15. Directional Beam Antennas ..... 59**

15.1 The Monoband Yagi ..... 59

15.2 Trapped Multi-Band Yagis ..... 62

15.3 The SteppIR Antenna ..... 65

15.4 The Log-Periodic Array ..... 65

15.5 Directional Cubical Quad and Delta Loop Antennas ..... 66

15.6 The Quagi ..... 72

**16. Gain Versus Front-to-Back ..... 73**

**17. Feed-Lines Commonly Called Transmission Lines ..... 74**

**18. Antenna Safety ..... 76**

18.1 Erecting Antennas on Masts ..... 76

18.2 Tower Safety ..... 76

# 1.

## ***Why All The Fuss About Antennas***

Definition: An antenna is a piece of metal, a conductor of electricity, to which you connect the radio. It radiates your signal and receives the signals you want to hear.

Definition: An antenna system consists of the antenna, the feed-line, and any matching unit. Most antennas are made of copper or aluminum, while most mobile antennas are made of stainless steel. A feed-line consists of two conductors that carry the signal to and from the radio and to and from the antenna. A matching unit can be an antenna tuner, a series matching section, or one of several different kinds of matching circuits at the feed-point.

Does the type of antenna make much difference? Here is an example: Once in 1959 two of us were involved in testing two antennas on 15 meters. The late R. Lynn Kalmbach, W4IW, using one antenna received a 30-dB better signal report on his antenna from a station in England than we did on our antenna. (Decibel or dB will be explained later). Thirty dB means his signal appeared that he was running 1000 times more transmitter power than we were. At that time, we didnt live that far apart so we couldnt blame it on propagation. We both were running about equal power. Both antennas were at 50 feet. The comparison proved that a good antenna could make a difference. Lynn used a home-built G4 ZU mini-beam; we were using a 15-meter 2-element Mosely Mini-Beam, which had short loaded elements. Evidently, it had a lot of loss.

Another example: Today we hear people breaking in to our ragchews with signals almost level with the noise. Why is that? The reason is they are using the wrong antennas. Their signals are 20 to 30 decibels below everyone elses. They are making contacts, but just barely. The first question our group asks, "What kind of antenna are you using?" Experienced amateurs know the antenna can make all the difference. The guy with the poor signal sometimes will blame his bad signal report on band conditions or his lack of a linear amplifier. He is just sticking his head in the sand.

What we are trying to prove is next to your radio, the most important part of your station is the antenna. Many years ago, an old-timer said, "For every dollar you spend on a radio, you should spend two dollars on your antenna." That is also true today. You can do more to improve your signal strength with antennas than you can ever do by increasing your power. Having the ability to make contacts on a particular antenna doesnt mean it works well! Any antenna will make contacts, but your signals will be stronger on some antennas than on others. In addition, some antennas hear better than others.

## 2.

# *How Antennas Work*

First of all to work properly the antenna system must be matched to the transmitter. That is, all modern transmitters have an output impedance of 50 ohms. Antenna systems range in impedance of a few ohms to several thousand ohms. There are several ways to match them: pruning the length of the antenna, using an antenna tuner, matching the antenna with a length of transmission line called a matching section, or the use one of several matching systems at the antenna feed-point. Antenna matching is beyond the scope of the material found in this book and it is suggested you consult a more comprehensive antenna manual. Simple half-wave dipoles eliminate the need for a matching system because a resonant half-wave dipole has an impedance near 50-ohms.

You must understand electromagnetism to understand how antennas work. If you attach the two poles of a direct current (DC) voltage source to the two ends of a coil of wire, current will flow through the coil of wire and it will become magnetized. The magnetized coil is known as an electromagnet. Its magnetism will extend out to infinity becoming weaker with distance. Remove the voltage and the magnetic field collapses back into the coil. If an alternating current (AC) is connected to the coil, the magnetism moves out and collapses into the coil in step with the frequency of the alternating current source. The north and south poles of the electromagnet reverse on each half-cycle of the AC voltage.

If voltage and current can cause a coil to become magnetized, the reverse is true: A magnetic field can produce a voltage and a current in a coil. This is known as Faradays Principle of Magnetic Induction. A voltage will be produced at the ends of the coil of wire as you move any permanent magnet close to and parallel to the coil. The difference in this case is the magnet must be kept moving. Move the magnet in one direction, and current will flow in one direction. Reverse the direction the magnet is moving and the current will flow in the opposite direction. Moving the magnet back and forth produces alternating current. An AC generator spins a coil of wire between the two poles of a magnetic field. It doesnt matter which one is moving. The coil or the magnet can be moving. Any moving magnetic field can induce current in anther coil. It doesnt have to be a piece of metal we call a magnet. Imagine a moving magnetic field produced by AC circulating in and out of a coil. If that moving magnetic field passes through a second nearby coil, it will induce an alternating current in the second coil. A transformer uses this method to work. Transformers have a continuous iron core running from

the inside of one coil through the inside of the second coil to confine the magnetism inside the iron core. This makes the transformer nearly 100% efficient since only a little of the magnetic energy escapes.

A straight wire that has an AC current flowing through it also has a magnetic field surrounding it. But it is a weaker field than is produced by a coil. The magnetic field from the wire radiates out into space and becomes weaker with distance. The radiating magnetic field from a wire is known as “electromagnetic radiation” and a radio wave is one type of it. The wire that radiates becomes the transmitting antenna. Some distance away, a second wire in the path of these waves has current induced into it by the passing electromagnetic waves. This second wire will be the receiving antenna. The voltage in the receiving antenna is many times weaker than the voltage in the transmitting antenna. It may be as weak as one-millionth of a volt or less and still be useful. The receiving antenna feeds that voltage to the amplifiers in the receiver front-end where it is amplified many thousands or millions of times.

The dipole antenna is made of a wire broken in the center and where broken, each half of the wire connects to an insulator that divides the wire in two. Two wires from the voltage source, which is the transmitter, are connected across the insulator. On one side of the dipole, the current in the form of moving electrons flows first from the voltage source toward one end of the dipole. At the end, it reflects toward the voltage source. The same thing occurs on the other half of the wire on the other half cycle of alternating current. An antenna that is the right length for the current to reach the far end of the wire just as the polarity changes is said to be resonant. Because electricity travels at 95% the speed of light in a wire, the number of times the polarity changes in one second (frequency) determines how long the wire has to be in order to be resonant.



# 3.

## ***Polarization Of Electromagnetic Waves***

Electromagnetic waves travel away from the wire in horizontal, vertical, slanted, or circular waves. If the antenna wire runs horizontal or parallel to the earth, the radiation will be horizontally polarized. A wire or conductor that runs at right angles to the earth produces vertical radiation. A slanted wire has components of both horizontal and vertical radiation. Crossed wires connected by proper phasing lines that shift the phase from one wire to the other wire by 90 degrees will produce circular polarization. Amateurs working orbiting satellites at VHF, UHF, and microwave frequencies use circular polarization.

When your high frequency signals are reflecting off the ionosphere, it isn't important if the other station's antenna has the opposite polarization from yours (the polarization does matter for line of sight communication). The reflected polarized waves passing through the ionosphere are slowly rotated causing fading signals (QSB). The reason the polarization of antennas is most important is that it determines the angle of radiation. Horizontally polarized antennas at ordinary heights used by hams produce mostly high angle radiation and weaker low angle radiation, but this doesn't mean there is no low angle radiation. It is there but is weaker than high angle radiation. However, you must put a horizontally polarized antenna up more than one-wavelength high to get a strong low angle radiation. One wavelength is 280 feet on 80 meters, 140 feet on 40 meters, and 70 feet on 20 meters. High angle radiation works nearby stations best and low angle radiation works distant stations (DX) best. A vertically polarized antenna produces mostly low angle radiation, with its high angle radiation being weak. For this reason, vertical antennas do not work as well as horizontal antennas do at ordinary heights for working stations less than about 500 miles away.

# 4.

## *Frequency*

The number of times the polarity of an AC voltage changes per second determines its frequency. Frequency is measured in cycles per second or Hertz (Hz). A thousand cycles per second is a kilohertz (kHz). One million hertz is a Megahertz (MHz). The only difference between the 60 Hz electric power in your house and radio frequencies (RF) is the frequency, but 60 Hz electricity in a wire also produces electromagnetic radiation just like radio waves. Useful radio waves start at 30 kHz and go upward in frequency until you reach the infrared light waves. Light is the same kind of waves as RF except light is at a much higher frequency. Light waves are used like radio waves when they are confined inside fiber optic cable. Above the frequencies of light are found x-rays and gamma rays.

The radio bands: The Long Wave Band (LW) starts at 30 kHz and goes to 300 kHz. The Medium Wave Band (MW) is from 300 kHz to 3000 kHz or 3 MHz. The High Frequency Band (HF) is from 3 MHz to 30 MHz. The Very High Frequency Band (VHF) is from 30 MHz to 300 MHz. The Ultra-High Frequency Band (UHF) is from 300 MHz to 3000 MHz or 3 GHz. Above these frequencies are several microwave bands which are defined as the Super High Frequency Band (SHF).

# 5.

## ***The Ionosphere and Modes of HF Propagation***

In the upper air around fifty miles and higher where the air molecules are far apart, radiation from the sun strips electrons from oxygen molecules causing the molecules to become ionized forming the ionosphere. The ionized oxygen molecules and its free electrons float in space forming radio-reflecting layers. Ionization of the ionosphere varies by the time of day, seasons of the year, and the sunspot cycle. The strength of ionization also varies from day to day and hour to hour. Since the height of the ionosphere varies, the higher the ionized layer becomes, the farther the skip will be.

### **5.1 The Ionosphere**

The part of the earth's atmosphere called the ionosphere is divided into three layers. The three layers are, from lowest to highest, the D layer, the E layer, and the F layer. Each layer has a different effect on HF radio propagation.

Being at a lower altitude, the D layer molecules are squeezed closer together by gravity than those in higher layers, and the free electrons reattach to the molecules easily. The D layer requires constant radiation from the sun to maintain its ionization. Radio waves at lower frequencies such as the frequencies of the AM broadcast band cannot penetrate this layer and are absorbed. The higher frequency signals are able to pass through the D layer. The D layer disappears at night causing AM broadcast stations to reflect from the higher layers. This is why AM broadcast signals only propagate by ground wave in the daytime and they can be received from great distances at night. Like the broadcast band, the D layer absorbs signals on 160 and to a lesser extent 80 meters during the day making those bands go dead. During solar flares, the D layer becomes ionized so strongly that all high frequency radio waves are absorbed, causing a radio blackout.

E-layer propagation is not well understood. Being at a lower altitude than F layer, the E layer is responsible for summertime short skip propagation on the higher high frequency bands. The skip zone is around 1000 miles, but at times when the E-cloud covers a wide area in the summer, double hops can be seen. A double hop occurs when the signal reflects from the ionosphere, then returns to the ground, reflects from the ground back to the ionosphere where

it is reflected back to the ground. A double hop can propagate the signal 2000 miles or more. The E-layer forms mostly during the day, and it has the highest degree of ionization at noon. The E layer like the D layer disappears at night. Even so, sporadic-E propagation can and does form at night. There is a minor occurrence of sporadic E propagation during the wintertime. On rare occasions, sporadic E propagation can surprise you by occurring anytime regardless of the sunspot cycle or the season of the year.

The F layer is the highest layer and it is divided into two levels: F1 and F2. At night the F1 and F2 merge into one layer. During the day, the F1 layer doesn't play a part in radio propagation, but F2 does. It is responsible for most high-frequency long distance propagation on 20 meters and above. However, the F layer makes it possible for you to work DX on the lower bands at night. Sunspots are responsible for the ionization layers and in years with high sunspot numbers, worldwide contacts can be made easily on 10-20 meters by F2 layer propagation. In years of low sunspot numbers, working distant stations is difficult on those bands. Consequently, 10 and 15 meters will be completely dead most days and 20 meters will go dead at night. In years of low sunspot numbers DX contacts are easily made at night on 160, 80, and 40 meters. The sunspot numbers increase and decrease in 11-year average cycles.

Since the curvature of the earth averages about 16 feet every 5 miles, an object 5 miles from you on perfectly flat earth will be 16 feet below the horizon. Because light travels in straight lines, you cannot see objects beyond the horizon. Radio waves travel in straight lines, but there are ways to get them beyond the horizon. This is referred to as propagation.

## 5.2 Ground-Wave Propagation

Ground wave works only with vertical polarization. One side of the antenna is the metal vertical radiator and the other side of the antenna is the earth ground. The surface wave in the air travels faster than the part of the wave flowing through the ground. The surface of the earth is curved like the curved part of a racetrack. On the curved track, a car on the outside of the track has to travel faster than the car on the inside lane to stay even, and the two cars travel in a curved path. Although the wave in the air travels faster than the wave on the ground, the two parts of the wave cannot be separated. Because of this, the radio wave also travels in a curved path that follows the curvature of the earth.

The AM broadcast stations use ground wave propagation during the day and skywave propagation at night. Since radio waves at lower frequencies conduct better through the ground, an AM broadcast station on 540 kHz will be many dB stronger than a station on 1600 kHz, if both run the same power. This fact is important in understanding why ground mounted verticals do not work as well at high frequencies as they do on the broadcast band.

## 5.3 Direct Wave or Line of Sight Propagation

Antennas located on high structures can “look” over the horizon and “see” the receiving antennas. Because refraction is involved, direct waves travel 20% farther than light waves due to scattering of radio waves by the environment. Trees and other foliage are invisible to HF radio waves. Direct wave propagation is possible at all frequencies, but this mode of propagation is seldom used on our high frequency bands, but it is the usual propagation mode

used by repeaters and others on VHF and UHF. If you watch TV on an outside antenna or on a “rabbit ears antenna,” you are receiving the signal by direct wave propagation.

## 5.4 Propagation by Refraction

Refraction occurs when the lower part of a wave travels slower than the top part of the wave because the wave is passing through two media. These media can be two layers of air at different temperatures or they can be air and a solid. One form of refraction is caused by a radio wave passing over a hill or ridge being bent as it passes over the obstruction. This is known as “knife edge refraction.” Another form of refraction occurs when layers of air of different temperatures bend the radio waves around the horizon. This is called tropospheric ducting. This mode of propagation makes long distance contacts possible at VHF frequencies. Tropospheric ducting does occur on 10 meters and lower frequencies and is noticeable when other forms of propagation are absent. On high frequency bands, many hams mistakenly call tropospheric ducting and direct wave “ground wave.”

## 5.5 Skywave Propagation

Skywave propagation occurs when radio waves are reflected from the ionosphere. Practically all HF communication is done by skywave. In the ionosphere, the waves are really refracted twice, and they just appear to be reflected. The reflections are frequency sensitive, meaning each ham band reflects differently from the others. Low frequencies, such as 80 meters, reflect mainly from the lower levels of the ionosphere and the reflected signal comes nearly straight back down. This causes 80 meters to propagate to points from local out to more than a few hundred miles in the daytime. At night, when the D layer and E layer are absent, signals striking the ionosphere at lower angles may propagate many thousands of miles on 80 meters. On the bands from 20 to 10 meters, high angle signals pass straight through the ionosphere and do not reflect back down to the nearby stations. The low angle signals on these higher bands reflect from the ionosphere near the horizon and return to the Earth some miles away. The in-between region cannot hear the transmitted signals nor can you hear signals coming from this region. The in-between region is called the “skip zone.” Only when the ionosphere is weakly ionized do you have a skip zone on 80 meters.

Another interesting type of skywave propagation seen on the higher HF bands is called chordal hop propagation seen frequently in trans-equatorial (TE) propagation, which is propagation crossing the equator. When this occurs, signals entering the ionosphere are trapped inside the F2 layer then they are finally refracted back to earth across the equator thousands of miles away. There is no propagation between the signal entry point and the exit point. This is skip in the extreme. On many occasions, we have worked stations far away across the equator in the southern part of South America and stations in between could not be heard. We have frequently worked VQ9LA in the Chagos Archipelago located in the Indian Ocean. The path to The Chagos Archipelago is across Europe and the Middle East and finally across the equator to his location in the Indian Ocean. One time when he was working Europe and North America at the same time, we could not hear the European stations because our path to him was via chordal hop propagation. Another way of describing chordal hop propagation is to call it ionospheric ducting.

Skywave propagation sometimes produces an effect called “backscatter.” What happens is the radio waves that strike the ionosphere, instead of only reflecting far away from the transmitting station, part of the signal reflects backwards toward the transmitting station. Stations that are too close to hear each other by direct wave can communicate by the backward reflecting waves. Both stations that communicate by backscatter must point their directional beam antennas in the same direction although their direction toward each other may be at some other azimuth. Backscatter will confuse front-to-back measurements of directional beam antennas. This is because, when you turn the back of the antenna toward the station you are hearing, you may be able to hear him on backscatter from a direction opposite from him. You will be hearing him from the ionized atmospheric cloud in the opposite direction. During intense solar magnetic storms, when aurora occurs at high latitudes, stations are able to communicate by backscatter on VHF and UHF by both stations pointing their directional beams toward the aurora. This will be due north for stations in the Northern Hemisphere and due south for stations in the Southern Hemisphere. Audio from aurora backscatter will have a “wispy” sound.

## 5.6 Greyline Propagation

Greyline propagation occurs when the sun is low in the sky near dawn or dusk, although we have seen greyline propagation occur as early as two hours before sunset or as late as two hours after sunrise. It is often used to work stations on the other side of the world on 160 and 80 meters. For example, at certain times of the year when it is approaching sunset here in the States, the sun will have just risen in Asia or Australia and vice-versa. At that time, radio waves propagate along the semidarkness path that encircles the Earth called the greyline. Both locations must be in the greyline in order to make 2-way contacts. The tilt of the Earth makes the position of the greyline change as the seasons change. Greyline propagation occurs between any two locations for a brief period of a few weeks. Afterwards, different places fall into the greyline. For several weeks in the fall of the year, an interesting example of greyline propagation occurs in the southeastern part of the U.S. On 3915 kHz, the BBC outlet in Singapore can be heard for about an hour before sunset coming in by greyline propagation. Stations to the east hear it before we do. Stations farther to the west can hear the fading signals after it fades out here because the greyline moves as the earth rotates. For those hearing it, the signal fades in, it peaks, and it slowly fades out.

## 5.7 Long Path Propagation

Long path propagation occurs when signals propagate the long way around the world. It can occur on any band. It usually occurs from stations on the opposite side of the world from you. We have worked South Africa via long path by beaming northwest early in the morning on 20 meters. When this happens, we are working him long path through the nighttime side of the earth. Since at all times half the Earth has daytime and half the Earth has night, long path propagation is determined by whether the signal is propagated through the nighttime path or daylight path. Sometimes the daylight path will bring in stations by long path propagation and at other times the darkness path provides long path propagation. One night on 20 meters, we heard a station in India coming in short path and long path simultaneously, but the short path was stronger. At the same time, California was working India by long path and they could not hear him short path. They were working him through the daylight path, and he was stronger here on the East Coast via the nighttime path.

## 5.8 160-Meter Propagation

Each amateur band propagates signals differently. The 160-meter (1.8-2.0 MHz) band is our only MW band and it acts similar to the broadcast band. It is primarily a nighttime and wintertime band as it suffers from high summertime static (QRN). Most hams that use this band for nearby contacts use horizontal dipoles or inverted-V antennas. Some hams use vertical antennas on this band to work distant stations (DX). These DX contacts are made in the fall and wintertime at night via F layer or greyline propagation when the static levels are low. Dipoles and inverted-V antennas do not work well for DX on this band.

## 5.9 80-Meter Propagation

The CW part of this band is called the 80-meter (3.5-4.0 MHz) band and the voice part of the band is known as 75 meters. Like 160 meters, 80 meters suffers from the same QRN in the summertime. Working DX on this band is a popular avocation during the fall and winter. However, 80 meters is used primarily for working nets and ragchewing. Eighty meters is primarily a nighttime band. This band can vary from being open most of the day in years with low sunspot numbers to being closed during the middle of the day in years with many sunspots. Many DX contacts have been made using dipoles and inverted-V antennas, but a vertical with many ground radials will be better.

## 5.10 40-Meter Propagation

The 40-meter (7.0-7.3 MHz) band has propagation that can act like either 80 meters or 20 meters. It just depends on the stage of the sunspot cycle. During the years with high sunspot numbers, nearby contacts are possible all day. At night, the skip lengthens making contacts possible to those parts of the world where it is still dark. Working DX on 40 meters is a nighttime or greyline event. When the sunspots are low, 40 meters may have long skip during the day, and nearby contacts may be impossible or they may be very weak. During the time when we suffer from low sunspot numbers, many DX contacts are made during early morning, late afternoon, and at night.

If your primary interest on 40 meters is SSB, our 40-meter voice band is a broadcast band in Regions 1 and 3. Region 1 is Europe, North Asia, and Africa and Region 3 is the Pacific, Southern Asia, and Australia. The top part of 40 meters is a voice band in Region 2, which is North and South America. To work SSB on 40 meters at night, you will have to find a frequency between broadcast stations. Strong broadcast stations heard at night begin to fade out slowly as the morning sun rises and moves higher in the sky. As the sun's angle declines in the afternoon, the broadcast stations begin to break through the noise becoming stronger as the sun begins to set. It is only in the middle of the day when no broadcast stations are heard on 40 meters.

Since DX stations in region 1 and most of region 3 can only transmit below 7100 kHz, working DX on 40-meter SSB is still possible. Stations in those regions will have to transmit below 7100 kHz. (Australian and New Zealand amateurs can operate up to 7200 kHz.) They call CQ and announce where they are listening in our voice band above 7150 kHz. This is what is called "working split."

## 5.11 30-Meter Propagation

The 30-meter (10.1-10.15) band has such a narrow frequency that the only modes allowed here are CW and digital modes. That means no SSB. Propagation here is much like 40 and 20 meters. Unlike 20 meters, this band stays open longer at night during years with low sunspot numbers. During the daylight hours, it has much shorter skip than 20 meters. In the United States, we are allowed only 250 Watts.

## 5.12 20-Meter Propagation

The 20-meter (14.0-14.35 MHz) band is the best DX band because it is open for long-skip for more hours than any other band and it does not suffer from QRN as the lower bands. In years of high sunspot numbers, short-skip and long-distance DX can be worked at the same time during daylight hours. Although DX is there most of the time, most of the DX worked is at sunrise, sunset, and all night during peak sunspot years. During the years of low sunspots, it is common to work into Europe and Africa during the day and into Asia and the South Pacific during the evening hours and early at night. Low sunspot numbers cause 20 meters to go dead for east to west contacts at night an hour or so after sunset, but there is some TE propagation. During periods of moderate sunspot numbers, the propagation on this band is a blend of propagation of low and high sunspot years.

## 5.13 17-Meter Propagation

The 17-meter (18.067-18.167 MHz) band propagation acts much like 20 meters except it is affected more by low sunspot numbers than 20 meters. In periods of low sunspot numbers, this band does not stay open as late as 20 meters, fading out as the sun begins to set. Yet, the 17-meter band does stay open all night when the sunspot numbers are high. The propagation on this band is like a blend of 20 meters and 15 meters, but it is closer to 20 meters. Most users of this band use dipoles and other simple antennas since triband beam antennas wont work here.

## 5.14 15-Meter Propagation

15 meters (21.0-21.45 MHz) is a fantastic DX band during the high sunspot years. This band may be open for 24 hours, and it is common to work more than 100 countries during a contest weekend on this band. Many have worked more than 300 different countries on 15 meters. In years of low sunspot numbers, 15 meters may be completely dead for several days in a row. When it opens during those years, you may hear only the Caribbean, South America, and on rare occasions the extreme southern part of Africa via TE propagation.

## 5.15 12-Meter Propagation

The 12-meter (24.89-24.99 MHz) band is much like 15 meters, but it is affected more by sunspot numbers. Because this band is little used, many hours can pass without hearing any amateur signals. Occasionally you will hear South American Citizen Band “pirates” on lower



sideband. It is mostly a daytime band but openings to Asia and the South Pacific are common early at night during peak sunspot years. The reason this band is little used is that tri-band beam antennas don't cover this band.

## 5.16 10-Meter Propagation

The 10 meter (28.0-29.7 MHz) band that is most affected by the sunspot numbers. You may have noticed in this discussion, the higher the frequency, the more it is affected by sunspots. During peak sunspot years, 10 meters can be open some days for 24 hours. Mostly it is a daytime band. When they are at the peak, the sunspots enable you to work worldwide with power as low as 5 Watts. A 10-meter confirmed country total of over 250 is common. In the low sunspot years, the band can be closed for days. 10 meters can open for very short skip by sporadic E propagation during the summer months. Very short skip means contacts as close as 200 miles out to 1000 miles. Sporadic E propagation can suddenly occur without regard to the sunspot numbers.

# 6.

## *Standing Wave Ratio*

A standing wave ratio bridge is used to measure the standing wave ratio, or SWR. SWR is an indication of how well the radiating part of an antenna is matched to its feed-line or how well the tuner is matching the antenna system. Most amateurs pay far too much attention to SWR. An SWR reading below 2:1 is acceptable, because the mismatch is so small that the feed-line loss can be ignored. If you are using a modern transceiver, its power may fold back to a lower power output above this SWR level.

When you have mismatch between the feed-line and the antenna, part of the power feeding the antenna system reflects back toward the tuner and the transmitter. The part of the power going toward the radiating part of the antenna system is called forward power. The part reflected back down the feed-line is called reflected power. The larger the mismatch the larger the reflected power will be.

If the feed-line and antenna are not matched, waves traveling toward the radiating part of the antenna system meet the waves being reflected back down the feed-line. The waves interfere with each other, and at certain points along the feed-line, the amplitudes of both waves combine. This will result in a current maximum to be found at that point; and at that point, the current will appear to be standing still. The length of feed-line and the frequency will determine where this point occurs. At another point, the forward and reflected waves interfere, and they subtract from each other. At that point, there will be a current minimum. If you could visualize this phenomenon, you would see a series of current maximums and minimums standing still along the feed-line. This is why we refer to them as standing waves. At different points along the feed-line, where you have high current, you will have low voltage, and where you have low current, you will have high voltage. At any point along the feed-line, multiplying the voltage times the current will equal the power in Watts. When the feed-line is matched to the antenna, current and voltage remain the same all along the feed-line because there is no reflected current to interfere with the forward current.

As happens with the current, the voltage will also appear to be standing still. The voltage maximums and voltage minimums will not be at the same locations as the current maximums and minimums. SWR is the ratio of the maximum voltage to the minimum voltage on the line. It is called *Voltage Standing Wave Ratio* or VSWR, but we shorten it to just SWR. There is

also a current SWR or ISWR, and it is the same value as the VSWR. For example, if the standing wave voltage maximum is 200 volts and the minimum voltage is 100 volts, the VSWR will be 2:1. If the voltage maximum and voltage minimum are equal, the SWR will be 1:1. If the voltage minimum is zero, the SWR is infinite.

In measuring SWR at the transmitter, you need to realize that feed-line losses affect the SWR readings. If the feed-line losses are high, much of the power reflecting back from the antenna will be lost, and the SWR reading on the meter will indicate it is lower than it actually is. If a feed-line is so lossy that it consumes all forward and reflected power, it will measure an SWR of 1:1.

When measuring SWR on an antenna having a small amount of reflected power, the length of the feed-line between the bridge and the antenna may affect your SWR reading. An example of this is a 70-ohm antenna being fed with 50-ohm coax. Different lengths of feed-line will give you small differences in SWR readings because at certain lengths, the mismatched feed-line starts to act like a series matching section. In the case of a 70-ohm antenna fed with 50-ohm coax, if the feed-line is a half wave long, the SWR will measure 1.4:1. At some particular length of feed-line and on one frequency, the SWR will measure 1:1 because that length of that feed-line transforms the impedance to make a match. Some hams have adjusted their feed line length to get a perfect match. This is called “tuning your antenna by tuning your feed-line.” With other feed-line lengths, you will measure something different. Suppose the impedance of the feed-line and the antenna are perfectly matched. Then there is no reflected power. You will get a 1:1 reading on the SWR-bridge with any length of feed-line.

There is a myth that reflected power is burned up as heat in the transmitter. The reflected power coming back down the feed-line sees an impedance mismatch at the transmitter or tuner and it reflects back up again. The reflected power does not get back into the transmitter. Because the reflected power reflects back and forth, the radiating part of the antenna system absorbs most of the power being reflected back up each time. All of it eventually is radiated except for the power lost in the feed-line. The losses in a real feed-line will burn up some of the power on each pass. This is why the feed-line loss increases with SWR.

Built-in tuners are found in most modern transceivers. If yours doesn't have one, then you can use an outboard tuner to give the transceiver a proper load. The place you want a 1:1 SWR is between the output of a transceiver and antenna or between the transceiver and the input of a tuner in order for the transmitter to deliver its maximum power. Because built-in tuners are in most modern transceivers, many hams use them to match antenna systems having high loss.

# 7.

## ***Real Antenna Systems***

In this book, we will be talking about the losses that rob an antenna of its maximum performance. The ideal antenna system will radiate 100% of your transmitter power on all bands without a tuner and in the direction you want to work. Such an antenna system does not exist. Many new hams succumb to antenna advertisements making claims that are exaggerated. No antenna will have low SWR, work all bands without a tuner, and radiate efficiently at the same time. A dummy load has a low SWR and will load up on all bands, but it will not radiate a signal. A resonant coax-fed dipole antenna will have a low SWR and will radiate efficiently on the band for which it is resonant, but it will not work well on all bands. For example, if the tuning range of your tuner has a sufficient range, you will be able to load up any antenna with it, but it will not necessarily radiate a signal efficiently. It may have high tuner and feed-line losses.

When you choose an antenna, you must decide how much loss you can accept. DXers and hams that work weak signals at VHF frequencies try to eliminate as much loss as possible. If your contacts are going to be made under good band conditions and without much interference, you can get by with high losses. In that case, coax-fed antennas used on bands where they are not resonant will allow you to make contacts. You can be greatly surprised by how little radiated power can be used to make contacts under ideal conditions. If you want to make contacts regularly under changing band conditions, you will want to eliminate as much loss as possible and use antennas with gain. Lower loss will enable you to hear weaker signals.

Nothing will take the place of resonant half-wave dipoles, not because they radiate more efficiently, but because they don't require lossy tuners and don't have high coax losses. Remember that all antenna systems have compromises.

# 8.

## ***Half-Wave Resonant Dipole Antennas***

Most dipoles consist of two pieces of wire of equal lengths with one of the two ends connected together through an insulator. The far ends of the wires are also connected to insulators. The two conductors of a feed-line are separated and connected across the gap at the center insulator. The antenna is held up by rope that connects the insulated ends of the antenna to two supports. It is a “balanced” antenna, because equal currents flow on both halves of the antenna. Coax is an unbalanced feed-line. (The possible effect of using an unbalanced feed-line on a balanced antenna like a dipole will be discussed later.) The dipole that is stretched between two high supports is called a flat-top dipole, distinguishing it from other configurations.

### **8.1 The Half-Wave Flat-Top Dipole**

The simplest antenna system of all is the half-wave resonant dipole fed with coax and no tuner. The only reason for using a half-wave resonant dipole antenna is to eliminate the need for a matching device such as a tuner. The feed-point impedance will be near 50 ohms at ordinary heights and they can be fed directly with 50-ohm coax from the output of today's modern radios. The two halves of a dipole are fed 180 degrees out of phase, meaning when one side is fed positively, the other side is fed negatively. That is why a feed-line has two conductors. Of course, the sides swap polarity on each half cycle.

If you could visualize the current flowing on the half-wave dipole, the current will appear to be standing still. The maximum current will be seen at the center of the wire and no current will be at the ends. This occurs because the electrons flowing out to the ends reflect back toward the center where they meet the next wave and the current is reinforced there. The minimum voltage occurs at the center and the maximum voltage occurs at the ends of the half-wave resonant dipole. If you were to measure the voltage and the current at any point on the dipole wire, the voltage times the current will equal the power in Watts.

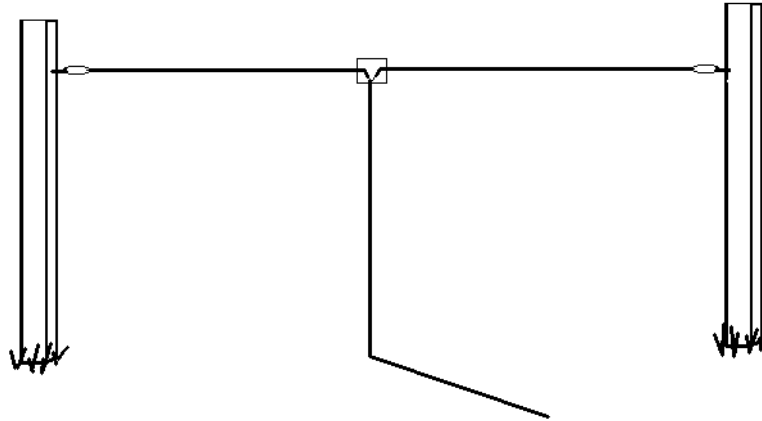

Figure 8.1: Flat Top Dipole

## 8.2 Inverted-V Dipole

Another configuration for the half wave resonant dipole is one having one support in the center and the ends stretched down toward the ground. The single support can be a tree, mast, or tower. The ends of a dipole have high RF voltages on them, and need to be at least 10 feet above ground for safety. This antenna is called an “inverted-V,” because the shape of the dipole looks like a “V” turned upside down. Most dipoles illustrated in this book can be put up in the inverted-V configuration. This configuration works well because the current is concentrated on the middle two-thirds of the antenna at the apex. The current in an antenna is what is responsible for the radiation. The ends of the antenna have very little current in them and it doesn't matter if the ends are close to the ground. The middle of the antenna is up high where the radiation is taking place and that is the place you want the radiation to be. An inverted-V has an advantage that the horizontal space required for it is less than what is needed for a flattop dipole. The angle between the wires on an inverted-V needs to be greater than 90 degrees. The gain of an inverted -V is 0.2 dBd and it has a radiation pattern nearly omni-directional. Since it is easy to construct and works so well, the inverted-V is the most commonly used dipole. An explanation of the decibel will come later.

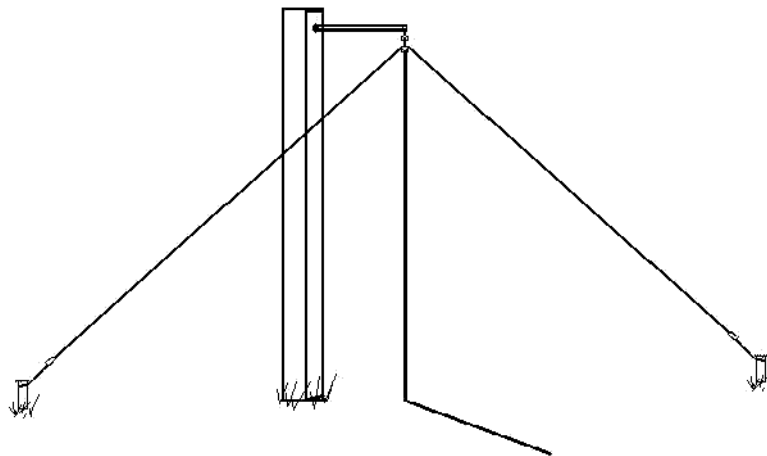
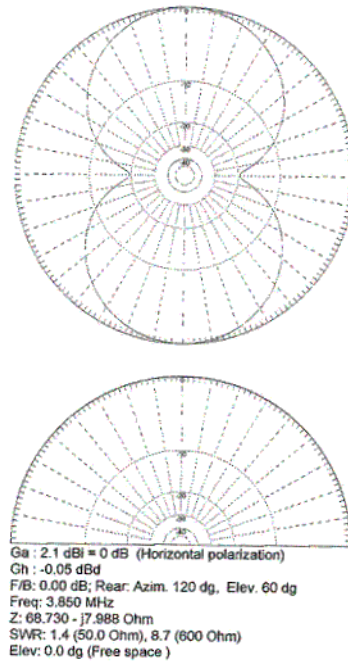

Figure 8.2: The Inverted-V Dipole



**Figure 8.3: Radiation Pattern of Inverted-V for 80-Meters at 65 Feet**

In *Figure 8.3: Radiation Pattern of Inverted-V for 80-Meters at 65 Feet* on page 19, the top graph shows how the radiation would appear to you, if you were situated above the dipole and you were looking down on it. The plane of the antenna runs from side to side on the top graph, and that graph demonstrates only a 5-dB null off the ends of the antenna. Therefore, it is essentially omnidirectional. The bottom graph shows how the radiation would appear if you were looking at the antenna from the end of the wire. As you can see, the pattern shows no radiation at the horizon and its maximum radiation is at about 40 degrees above the horizon, and the radiation straight up is only down 3 dB from its maximum. This antenna was modeled on 80 meters with the apex at 65 feet above ground and the ends at 35 feet.

It is a myth that a horizontal antenna orientation makes a difference on 80 meters at heights used by most amateurs. I have heard many amateurs say on 80 meters, “The reason my signal is weak to you is because you are off the end of my dipole.” The radiation pattern from a dipole is essentially non-directional until the dipole is elevated more than a half wave, that is about 125 feet on 80 meters, and it is 65 feet on 40 meters. The main reason it makes no difference regarding orientation is because propagation for signals closer than 500 miles (the distance of most 80 meter contacts) is essentially by high angle radiation nearly straight up and down. Only signals radiated and received at low angles make a difference in antenna orientation even at low heights above ground. At low heights, there are nulls about 3 to 4 dB off the dipole ends.

### 8.3 Dipole Shape Variations

The wire of a dipole doesn't have to be run in a straight line. A dipole does not have to be perfectly horizontal. That's the way it is usually depicted in books and magazines, but you can bend the legs of the antenna up, down or sideways.

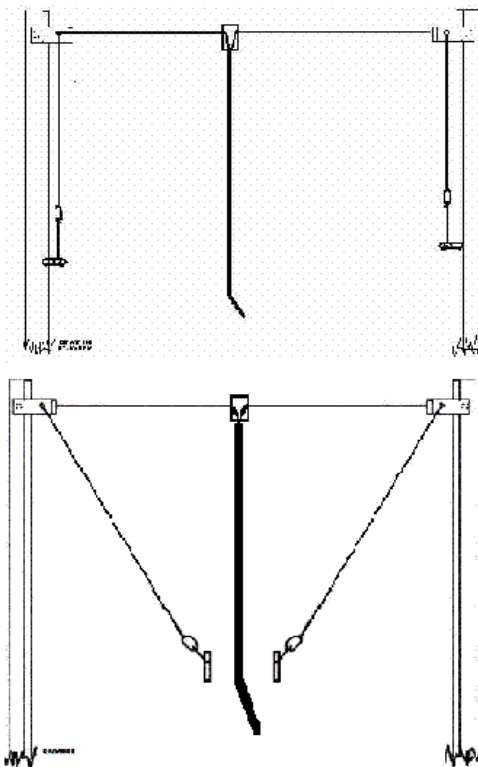

Figure 8.4: Two Dipole Shape Variations

If you make either wire one-half wavelength long and carefully prune it to resonance, you can use it without a tuner on and near its resonant frequency. Both antennas have the current part at the top where most of the radiation takes place. The vertical parts of these antennas radiate a weak vertically polarized wave. The only reason these dipoles are contorted this way is to make them full-sized and to fit in the available space. Other shapes are possible, and you can be creative at your location.

There are many more dipoles than the ones just described. We explore the other kinds of dipoles in *Section 8. Half-Wave Resonant Dipole Antennas* on page 17.

### 8.4 Calculating the Length of a Half-Wave Resonant Dipole

The approximate length in feet of a half-wave resonant dipole is found by dividing 468 by the frequency in MHz. The actual length of it will be determined by several factors. Using larger diameter wire will make the dipole resonate lower in frequency. Therefore, to make it resonate at the higher desired frequency,



It must be shortened. Raising a dipole higher above ground will make it resonate higher in frequency. An insulated wire will make the dipole resonate lower in frequency than a bare wire.

Using the above formula, cut the antenna a little longer than the calculations say. If the SWR is best at a lower frequency than you desire, the antenna will have to be made shorter by pulling the excess wire through the end insulators, folding the ends of the extra wire back on itself. Then wrap the ends of the overlapped wire on itself so it won't come loose. This causes the excess wire to "short" itself to the rest of the antenna. If you are using insulated wire, you will need to cut off the excess wire. The reverse is true if the antenna resonates too high in frequency. The extra wire can be let out to make it resonate on a lower frequency. This is why you originally cut the wire a little longer.

## 8.5 The Decibel

The decibel (dB) is a unit of measurement for comparisons of the ratio of power, current, and voltage and is the term we will use in comparing antennas in this book. At one time, antenna comparisons were made using a dipole as a standard, but today most comparisons use the isotropic radiator as a reference. An isotropic radiator is an imaginary antenna that radiates equally well in all directions. It has no gain. The terms "dBi" and "dBd" are used to label which reference is being used. In this book, we will use the dipole as a standard for the most part.

How do you derive decibels from power ratios? The formula for power ratios is  $\text{dB} = 10 \log P1/P2$ . For voltage and current, the values are doubled. Formulas of this type are beyond the scope of this book. Doubling the power will produce a 3 dB stronger signal. Double the power and double it again will equal a 4 times power increase and that gives 3 dB plus 3 dB or 6 dB. Double 4 and that is a power increase of 8 and that adds 3 more dB for a total of 9 dB. Increasing the power from 1 Watt to 10 watts or increasing it 10 times will give a 10-dB increase. Multiply 10-Watts times 10 give us 100 watts, which adds another 10 dB above 1 Watt for 20 dB. Therefore, increasing the power another 10 times to 1000 Watts will produce a signal 30 dB stronger than 1 Watt.

Your receiver, if modern, will have a signal strength meter or "S Meter." That meter is calibrated in "S-Units" from one to nine and decibels over S-9. S-9 is usually calibrated using 50 microvolts (uV) from a signal generator. Each S-unit is approximately a difference of 5 or 6 dB. Therefore, a reading of S-9 is about 6 dB stronger than S-8. Therefore, from S-0 to S-9 is 54 dB. On some low cost transceivers, the S-units and dB above S-9 are only relative signal readings and actually have nothing to do with decibels.

# 9.

## *Antenna Basics*

### 9.1 Resistances and Reactance

Two factors measurable in antenna impedance are resistance and reactance. When we refer to antenna resistance, we are referring to its radiation resistance. It is neither a resistance like the electronic component called a “resistor,” nor is it the same as the resistance found in all conductors. Those types of resistances, called “loss resistances,” change electrical energy into heat energy. Heat energy disappears by radiating out into its surroundings and it dissipates away to infinity. When we feed RF into the antenna, the energy put into the radiation resistance disappears from the antenna by radiation of electromagnetic waves, and that makes an antenna appear to have a resistor in it. Loss resistance robs power from the radiation resistance and lowers the efficiency of an antenna system, but the loss resistance in dipoles is very low if the feed-line loss is low. The efficiency of any antenna system is found from a ratio of radiation resistance and loss resistance. We can either calculate the loss resistance by the loss in the feed-line from published tables and by estimating the loss in tuning units. Feed-line loss and tuning unit loss can be measured, but that is beyond the scope of this book.

Antenna systems having reactance prevent the transmitter from delivering its full power and the reactance needs to be tuned out. There are two kinds of reactance: capacitive and inductive. Antennas have both. In antennas, reactance is a virtual reactance meaning the antenna acts as if there were a capacitor or an inductor in the antenna, but neither is there. You can only measure the sum of both reactances but not a value for either one. Using an antenna analyzer, you can determine whether the sum of the reactance is inductive or capacitive. Inductive reactance is a negative number and capacitive reactance is a positive number.

The reactance of an antenna forms the “J” factor in antenna impedance measurements. The “J” factor is measured in ohms and the reactance is expressed as + or “J” ohms depending on whether it is capacitive or inductive reactance. Capacitive reactance is expressed as +J ohms and inductive reactance is expressed as -J ohms. Capacitive and inductive reactance are opposite factors and one can cancel the other. An antenna having 6 ohms capacitive reactance or + J 6 ohms and an inductive reactance of J 5 ohms will result in an antenna with a reactance of 1 ohm capacitive or + J 1. Since one term is positive and the other term is negative, you subtract smaller value from the larger. The answer has the sign of the larger one. In antennas,

the reactance and resistance together determine the overall impedance of the antenna. The  $J$  factor is mentioned here only because you may see it in other books and on the extra class examination, but it will not be used further here.

A resonant antenna has equal amounts of inductive and capacitive reactance, and the sum of the reactance equals zero. As an example, when the inductive reactance equals  $J 5$  and the capacitive reactance equals  $+J 5$ , their sum equals zero. When the sum of the total reactance of an antenna is tuned to zero, its impedance is totally resistive. The use of an antenna analyzer will tell you if the antenna is too long or too short for resonance. The simplest way to tune out antenna reactance is to change its length. The sum of the reactance of a long antenna will be inductive, and the sum of the reactance of a short antenna will be capacitive. If an antenna is short because it won't fit your property, it can be tuned to resonance by putting an inductor (coil of wire) in each leg. These coils are called "loading coils." An equal amount of inductive reactance will cancel the excessive amount of capacitive reactance. An antenna with loading coils is described in section "X." When an antenna is too long, the sum of its reactance will be inductive, and a variable capacitor can be inserted in each leg to tune out the inductive reactance. This is seldom done because it is easier to shorten the antenna.

A resonant antenna may still have SWR if its radiation resistance is not exactly 50 ohms. Not many resonant antennas have a radiation resistance of exactly 50 ohms, and most real antennas have a small amount of SWR. An antenna is resonant only at one frequency per band. It will also be resonant on its harmonic frequencies, where its radiation resistance will range from high to very high. Hams talk about using resonant antennas. What is meant by this is they use an antenna on its fundamental frequency close to resonance, the resistance is near 50 ohms, and the SWR without a tuner is near 1:1.

To calculate the impedance of an antenna with both resistance and reactance requires a mathematical procedure called the Pythagorean Theorem. That type of math is beyond the scope of this book. However, you should know how to use the Pythagorean Theorem to solve impedance problems on the Extra-Class test. Otherwise, you will have to memorize the answers from the question pool.

## 9.2 Feeding Dipoles Efficiently

For maximum power transfer from transmitter to the antenna, the antenna system must be resonant, and the resistance of the load (antenna system) has to be equal to the internal resistance of the source (transmitter). Notice we said an antenna system, not the antenna, must be resonant. As mentioned previously, an antenna system consists of the antenna, the feed-line, and any matching networks (tuners). A tuner at the input end of the feed-line can make a non-resonant antenna system resonant, and have a resistance of 50 ohms, and that matches the internal resistance of the transmitter. A tuner will not change the SWR between the tuner and the dipole part of an antenna system, and will not remove the reactance from the dipole.

When the load of an antenna system does not match the source and the impedance is high, the load will not draw power from the source and high RF voltages will be present at the output of the final transistors. In this case, high RF voltages can damage the output transistors of the transmitter. When the impedance of the load is low, too much of the power may be dissipated

across the internal resistance of the transmitter possibly destroying the output transistors. These are the two reasons why transceivers “fold back” their power when the SWR is high.

It is a myth that the dipole part of an antenna has to be resonant to be efficient. When power reaches the radiating part of the antenna system, it obeys the “The Law of Conservation of Energy.” The Law of Conservation of Energy states, “Energy can neither be created nor destroyed. Only its form can be changed.” (What is important is to get the power to the dipole itself, because in some systems power is lost in the feed-line, especially when using coax with high SWR) The miniscule amount of power in the dipole that does not radiate is changed into heat, another form of energy. Because the dipole part of an antenna system is made of conductors with low loss resistance, 99% or more of the power reaching it will radiate regardless of its length if that length is reasonable. The loss resistance of the conductors of the radiating part of most antenna system is so low it can be ignored. (Short mobile HF antennas are an exception because they may be lossy because of the very high current flowing in them.)

Not all the energy fed into an antenna system will reach the antenna itself. If the system has a tuner, part of the power is lost in the inductor of the tuner and part is lost in the feed-line. When properly tuned, tuners using T-networks lose about 10% of the power and L-network tuners lose about 5% of the power being fed to them. Notice we said properly tuned. However, improper tuning of the antenna tuner may cause you to believe the feed-line is matched, but when this happens there is a very high circulating current in the inductor causing it to get hot. This causes extremely high losses, and very little power reaches the radiating part of the antenna. In addition, so much heat is produced in the inductor that it can be damaged. We melted the plastic insulation that forms the inductor on one tuner this way. For this reason, some hams don't like tuners, preferring to use resonant antennas. Read the instructions for your tuner for proper tuning or you may wind up with a poor signal and a damaged tuner. The resistive losses in the conductors of the feed-line and the dielectric losses in the feed-line also rob power from the system. These are the reasons for you to use the best tuners and feed-lines possible.

Another loss to be considered is feed-line radiation. Any energy that radiates from the feed-line does not reach the radiating part of the antenna, and it may be absorbed by near-by objects and may not radiate in the desired direction. When coax radiates, it is called common-mode radiation. If the feed line can radiate, it can also receive signals. This can be detrimental because the coax can then pick up noise from near-by power lines, etc. Feed-line radiation will also destroy the directional pattern of a beam antenna. The causes of feed-line radiation will be described in the next section.

As we pointed out earlier, when you are using a half-wave resonant dipole fed with low-loss coax without using a tuner, almost all of the power coming out of the transmitter will radiate. On its resonant frequency, the dipole is one of the most efficient antenna systems a ham can use. However, a half-wave resonant dipole has a finite bandwidth. Why use a tuner with resonant antennas? On 160 and 80 meters the bands are wide compared to the percentage of frequency. The width of 80 meters is 500 kHz and its frequency is 3500 kHz. The width of 80 meters is 14% of the frequency. The 350 kHz of 40 meters is 5% of the frequency and most of the band can be covered without a tuner. The 350 kHz width of the 20-meter band is 350 divided by 14000 kHz, or 2.5 % of the frequency, etc. The percentage of frequency for a band will determine if a resonant dipole will work the whole band without a tuner. If you are planning to move around on 160 or 80 meter bands, it makes sense to have a tuner, because the bandwidth of resonant dipoles on those two bands is narrow. For example, the normal 2:1

SWR bandwidth of an 80-meter dipole is less than 200 kHz and the band is 500 kHz wide. However, if you have an antenna resonant for the voice portion of the band, you can still use a tuner to work the CW part of the band without inducing more than a dB of loss. Except for 40 and 10 meters, full-sized resonant dipoles on the rest of the HF bands will have enough bandwidth for them to cover the whole band.

The best place to insert a tuner is up at the antenna feed-point. However, if it is placed there, you won't be able to reach the tuner's controls. Therefore, it is more practical to place it between the transceiver and the shack-end of the antenna feed-line. A piece of 50-ohm coax connects the radio to the tuner. With the tuner located in the shack, adjustments can be made. Remote automatic antenna tuners can be placed at the antenna's feed-point, but the disadvantage of them is that the ones available today will not handle high power.

A coax-fed dipole and a tuner should not be used to feed an antenna on its even harmonically related bands. The even harmonics are 2, 4, 6, etc, times the fundamental resonant frequency. If an 80-meter antenna being fed with coax through a tuner is used on 40 meters, it will put out a weak signal because the SWR will be around a hundred to one. Coax has a tremendous loss with SWR this high. Only a few Watts from a hundred-Watt transmitter will reach the antenna. However, you will be able to make contacts with those few Watts. If you want to use any antenna having high SWR, ladder-line has much less loss than coax. If you feed an 80-meter dipole on 40 meters using ladder-line and a tuner, it will only be slightly less efficient than a half-wave 40-meter coax-fed resonant dipole. However, the SWR will still be high between the tuner and the antenna, but this doesn't matter since ladder-line has an insignificant loss. Since the feed-point impedance will be high, the SWR will only be about 9:1 in the ladder-line because ladder-line is a high impedance feed-line.

Extremely short antennas may not work at all because of the above mentioned reasons. To reiterate, the extremely high capacitive reactance may make it impossible for its reactance to be tuned out and reactance prevents a transmitter from delivering power to the antenna. Even if you are able to tune out the capacitive reactance, tuning it out requires an inductor and most of the power will be lost in the inductor. Do not take the statement about the Conservation of Energy to mean you can put up any piece of wire and it will radiate your entire signal.

### 9.3 The Cause of Feed-Line Radiation

Contrary to popular myth, SWR in a feed-line will not cause it to radiate. The cause of feed-line radiation is unequal current in the two conductors of the feed-line. What are the causes of unbalanced current in a feed-line? They are an unbalanced feed-line feeding a balanced antenna; the feed-line being brought away from and parallel to one leg of the antenna; the antenna not being fed in its center; and one leg of the antenna being close to metal objects. In coax, unbalance causes RF to travel on the outside surface of the coax shield, and the shield radiates. When everything is balanced, coax normally has current flowing on its center conductor and on the inside of its shield. The shield prevents it from radiating.

Ladder-line will also radiate when it is fed from the output of a tuner not having a balun. Baluns are discussed in the next section. Since the output of a transceiver's tuner is unbalanced and feeding ladder-line directly from your transceiver's tuner, the currents in the ladder-line will not be balanced. When balanced, ladder-line has equal currents with a 180-degree phase difference, which produce waves that null each other out, and no radiation takes place. Hams

mistakenly refuse to bring ladder-line into the shack because of a fear of feed-line radiation, but ladder-line does not radiate when balanced. The simple cure for feed-line radiation is to use a balun at the antenna feed-point for coax and a balun at the output of the tuner when using ladder-line.

## 9.4 Baluns

The word “Balun” is a contraction of “balanced to unbalanced.” It is pronounced “bal un” like “bal” in “balanced and like “un” in “unbalanced”. Many hams mistakenly pronounce an “M” at the end of the word making it “balum.” A balun transforms the unbalanced transmitter output to a balance feed-line such as ladder-line. It is also used to connect an unbalanced feed-line such as coax to a balanced dipole. In the latter case, the balun is located at the antenna feed-point and is constructed so the balun takes the place of the center insulator.

There are two kinds of baluns: voltage baluns and current baluns. They both accomplish the same thing. The difference in baluns is in the way they are wound. A voltage balun produces equal voltage with opposite polarity at its output. As its name implies, a current balun provides equal currents with opposite polarity at its output.

Running the coax through ferrite beads can make a 1 to 1 current balun. In addition, you can build a 1 to 1 choke current balun by winding 8 to 10 turns of coax around a two-liter soda bottle and placing the coiled coax at the antenna feed-point. Any balun is designed to “divorce” your antenna from the feed line. It is used to prevent common mode radiation of coax, which makes the coax to be part of your antenna. You want it to be able to deliver all your power to the radiator itself. A choke balun does this perfectly, without using any ferrite beads or toroids. In most cases common mode coax radiation does not occur when a balun is not used, but it is preferable to use one to be safe.

Other baluns provide a step-up or step-down impedance transformation. A 4-to-1 balun steps up the impedance four times. It will transform a 50-ohm impedance to 200 ohms. This type of balun transformer is used at the output of tuners to increase the tuning range of a tuner 4 times. If a tuner without a balun can match 500 ohms, a 4-to-1 balun will increase the range of impedances it can match to 2000 ohms. Many hams think the 4-to-1 balun is used to match 50 ohms to 450-ohm ladder-line but it is not. It would take a 9-to-1 balun to match 50 ohms to 450 ohms, and it is not important to match the impedance to ladder-line.

A balun should always be placed at the input end of ladder-line or open wire feeders to prevent feed-line radiation. When using ladder-line a step up balun is commonly used although a 1:1 balun will work.

# Other Types of Dipoles

## 10.1 A Shortened Dipole Using Loading Coils

If you are unable to put up a full-sized dipole on your property, putting loading coils into the dipole could shorten the antenna. See *Section 11.1 End-Fed Zepp*. A short antenna has capacitive reactance and the capacitive reactance can be tuned out with a coil. The overall length of the shortened antenna will be determined by the amount of inductance in the coil. Pre-tuned antennas of this type are available from at least one manufacturer. The main problem with loaded antennas is they are very narrow banded. If the loading coils are wound with small diameter wire, the coils may introduce unwanted loss into the antenna. Loading coils can also be found in shortened vertical antennas for high frequency (HF) mobile use.

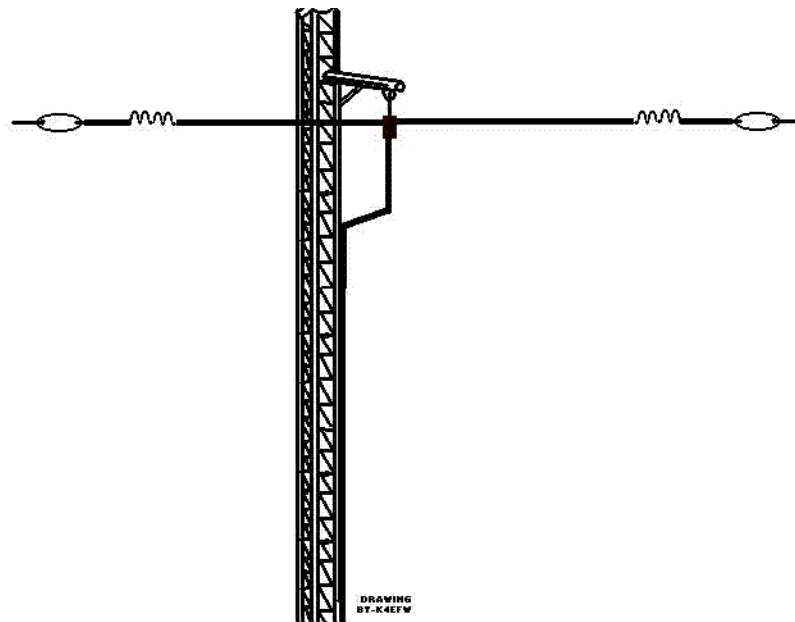

Figure 10.1: A Shortened Loaded Dipole

## 10.2 All Band Dipole

In *Figure 10.2: All Band Dipole*, a dipole is cut to a half wave on the lowest band you want to operate. Feeding it with ladder-line and a tuner makes it possible for you to work all the other higher bands. The only losses in this antenna system are the loss in the tuner and the very small loss in the ladder-line. This system is more than 90% efficient. As mentioned above the balun in the tuner will be used, or if your tuner doesn't have a balun, an external balun can be connected between the tuner and ladder-line with a short run of coax. Four-to-one baluns are the most commonly used ones for this arrangement.

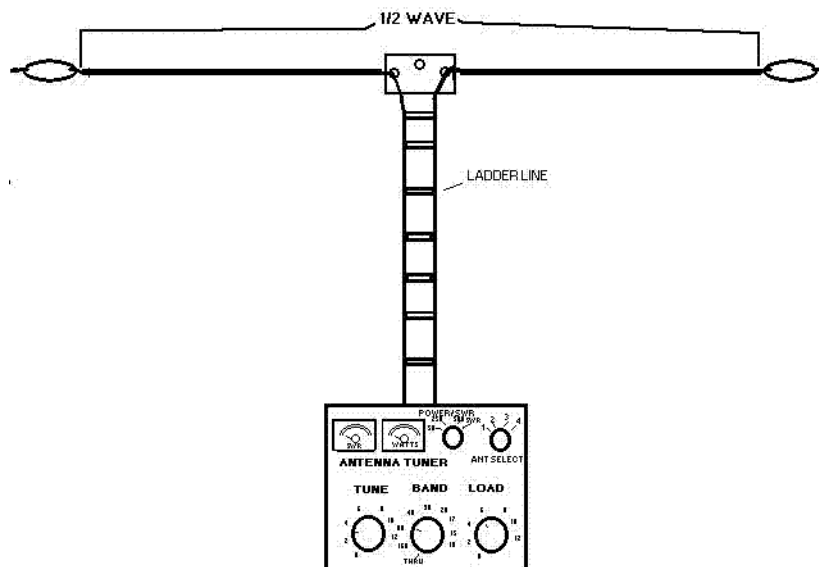

Figure 10.2: All Band Dipole

## 10.3 The Sloping Dipole

A lower angle of radiation can be achieved by tying one end of a half-wave dipole to a high support and the other end near the ground. It is fed with or without a balun with 50-ohm coax. The sloping dipole will show some directivity and have low angle gain in the direction of the slope. More directivity can be gained if the dipole is strung from a tower, and the tower is acting as a passive reflector. The sloping dipole is mostly a vertically polarized radiator and it works well for DX. Since the sloping dipole is fed in its center, it does not need to be grounded to the earth as a quarter-wave vertical does. Make sure the bottom end of a sloping dipole is at least 10 feet above ground because like all dipoles there is high RF voltage on its ends.

## 10.4 Half-Wave Resonant Sloping Dipole

In *Figure 10.2: All Band Dipole*, the field of maximum radiation is in the direction of the slope or toward the right side of the picture. The formula for the length of a sloping dipole is the same for any half-wave resonant dipole.



## 10.5 The Folded Dipole

The B&W Company makes a folded dipole that claims to have a good match on all bands and it does. However, on the low bands much of the power is burned up in the resistor that connects the two ends together. The power going toward the ends encounter the resistor and is consumed as heat. All that power is lost and does not radiate, and no power is reflected back to the feed point making the antenna have low SWR. On the higher bands, a large part of the power radiates before it reaches the resistor and the antenna is moderately efficient on those bands. On 80 meters the 90 foot-long dipole model will produce a signal at least 10 dB lower than that from a resonant dipole.

If you remember the single channel TV antennas used years ago, the driven element was a folded dipole. Folded dipoles are very broad-banded. That is the reason they were used for TV antennas since a TV channel is 4 MHz wide.

When constructing a folded dipole, the formula for calculating the length of it is the same as for any dipole. The folded dipole consists of two parallel conductors with the ends tied together. The conductors can be spaced from less than an inch to more than two inches apart when made from TV ribbon or ladder-line. At the ends, strip the insulation back several inches, Twist the bare wires together, solder them, and run them through insulators. The feed-point is in the center of only one of the two parallel conductors.

The feed-point impedance of a folded dipole at resonance is close to 300 ohms resistive and can be fed directly with 300-ohm TV twin-lead or a tuner with its balun. This antenna was very popular years ago when coax was expensive and 300-ohm TV twin-lead was relatively cheap. A length of 450-ohm can be substituted for the twin-lead. An alternate feed method is placing a 6:1 balun at the feed-point and then feeding it with 50-ohm coax. The folded dipole will not radiate its second harmonic, so it is not good for a multi-band tuner-fed antenna.

Another folded dipole type is the three wire folded dipole. We have seen this dipole only in books and do not know anyone who uses one. The feed-point impedance is 600 ohms resistive and is fed with home-built 600 ohm open wire feeders.

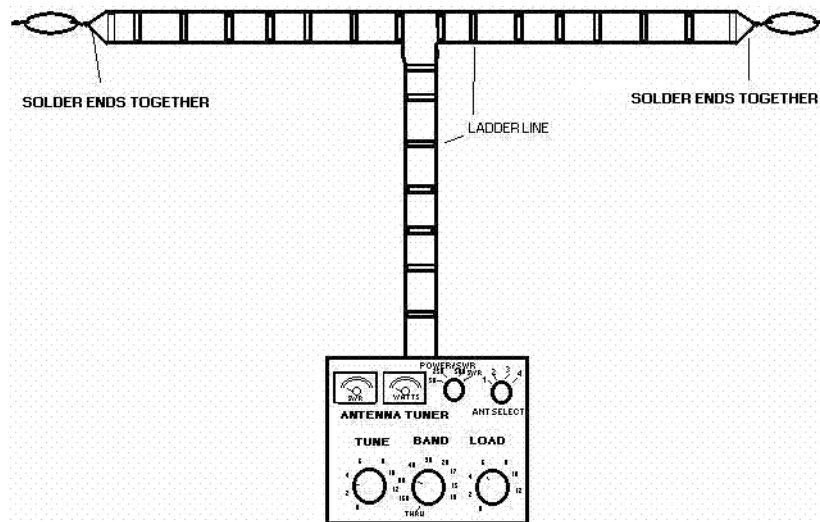

Figure 10.3: Folded Dipole

## 10.6 The Double Bazooka Dipole

The double bazooka is claimed by its users to be broad-banded, a quality especially interesting for those hams operating on 75/80 meters. Tests done at the A.R.R.L. have shown the double bazooka is only slightly more broad-banded than a regular dipole, probably due to the use of a large conductor (coax) for the center part of the antenna. The double bazooka will not transmit its second harmonic, and its users say it does not need a balun. Other users say it is quieter than a regular dipole.

The center of the antenna is made from RG-58 coax. To find the length of coax needed, divide 325 by the frequency in MHz. The coax forms the center part of the double bazooka and a piece of number 12 wire on each end completes the antenna. The length of each of the end wires is found by dividing 67.5 by the frequency in MHz. To increase the bandwidth some builders use shorted ladder-line in place of the number 12 wire, which makes the end pieces to be electrically larger.

The feed-point of the double bazooka is unique. At the center of the coax dipole, remove about 3 inches of the plastic covering, exposing the shield. Cut the shield in the center and separate it into two parts. Do not cut the dielectric or the center conductor. Leave the center conductor with its insulation exposed. On the feed-line strip off about 3 inches of outer insulation, separate the shield from the center conductor, and strip about 1 inches of the insulation from the center conductor. To attach the feed-line, solder the two exposed feed-line conductors to the two pieces of the separated exposed shield of the dipole center. It goes without saying: seal the feed-point to prevent water from getting in. At each of the two ends of the coax forming the center of the antenna, the coax is stripped back and the center conductor and shield are

shorted together and soldered. The end wires are soldered to the shorted coax ends, run to insulators at the end of the antenna, and the soldered joints are sealed against the weather.

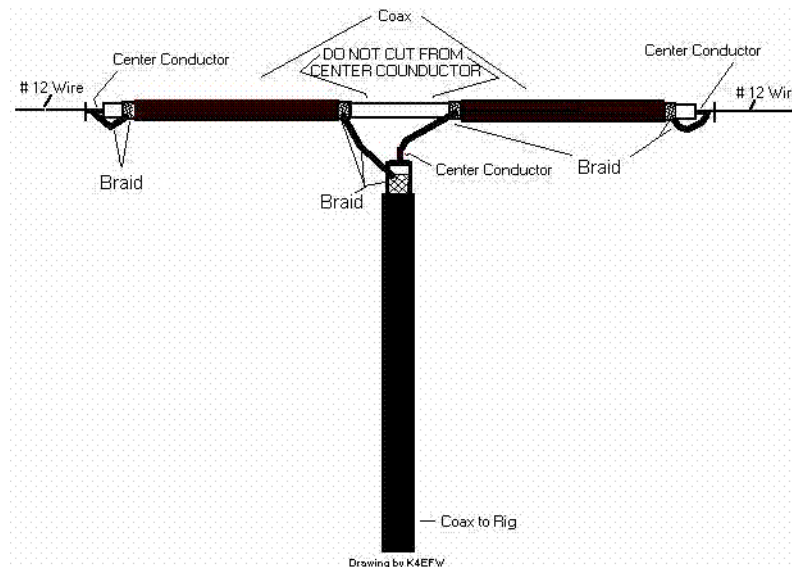

Figure 10.4: Double Bazooka Dipole

## 10.7 Broad-Banded Coax-Fed Fan Dipole

A broad-banded dipole for 75/80 meters can be constructed by attaching two equal length dipoles to the center feed-point and spreading the ends about 3 feet apart using PVC water pipe to separate them. The completed dipole looks like a bow tie. This makes the antenna to appear electrically to have that of a large diameter conductor. Because of this, the overall length will need to be shorter than a single wire alone. When we used the antenna, we found a length of 110 feet would cover most of the 75/80-meter band without a tuner. It is fed with 50-ohm coax. The use of a balun is optional. The antennas for most of the higher bands have enough bandwidth so they do not need broad banding.

## 10.8 Two-Element Collinear Dipole

The 2-element collinear dipole is an antenna that is a full-wavelength antenna having a 2-dBd gain. It can be fed with ladder-line and a tuner and used as a multiband antenna, or it can be fed with a quarter-wave-matching stub with 50-ohm coax cable to make it a single band array. In the stub matching system, a quarter wavelength of ladder-line is connected across the center insulator, and the opposite end of the ladder-line is shorted. A shorted quarter-wave piece of feed-line acts like an open circuit. Going from the shorted end of the ladder-line toward the dipole, there will be a point where a piece of 50-ohm cable will find a perfect match. The 50-ohm feed-point will have to be found empirically (trial and error).

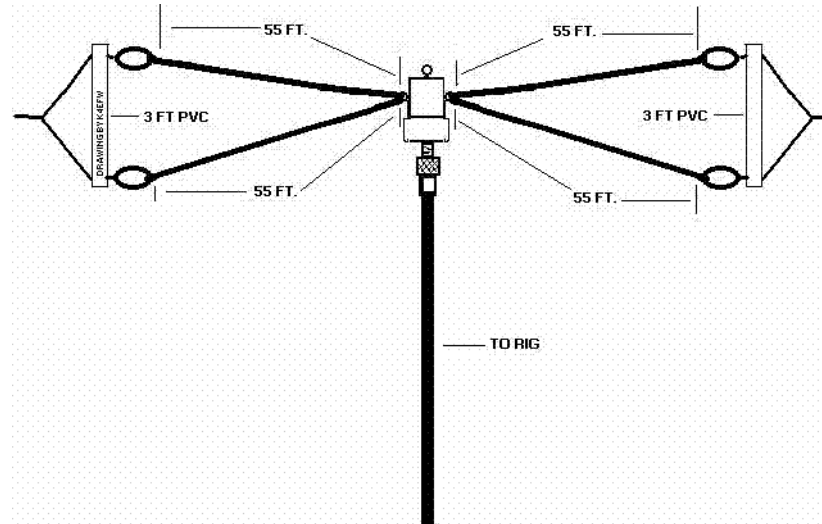

**Figure 10.5: Broad-Banded Fan Dipole for 80 Meters**

## 10.9 4-Element Collinear Dipole

The 4-element collinear dipole array consists of four half-wave segments connected end-to-end with an insulator between each two adjoining segments. The feed-point is at the center of the array. The antenna is fed with ladder-line through a tuner. A quarter wave shorted ladder-line stub hangs down vertically from the insulators between the inside and the outside half-wave segments. This stub provides a 180-degree phase shift so that all half-wave segments are fed in phase. This antenna has a 6-dBd gain and it radiates bi-directionally at an angle perpendicular or broadside to the plane of the wires.

This antenna is too long for most hams to use on 80 and 40 meters, and the stubs hanging vertically will be too close to the ground. For 20 meters, the four-element collinear array will be 97 feet long and the stubs will be 18 feet. To find the length of each half-wave segment, divide 468 by the frequency in MHz, and for the quarter-wave stubs, divide 246 by the frequency in MHz.

MFJ has begun marketing the four-element collinear monoband array. They have them for 20, 17, and 15 meters. This antenna is so easy to build that you can do it yourself. All you need is 5 insulators, antenna wire, and some ladder-line.

It will have no gain if you use it on bands for which it is not designed because the stubs are used as phasing lines. It is definitely not a multiband antenna.

It is possible to add more half-wave segments to the ends of this array to make it have 6, 8, 10, etc half wave segments. Adding more segments will add more gain and make the lobes narrower.

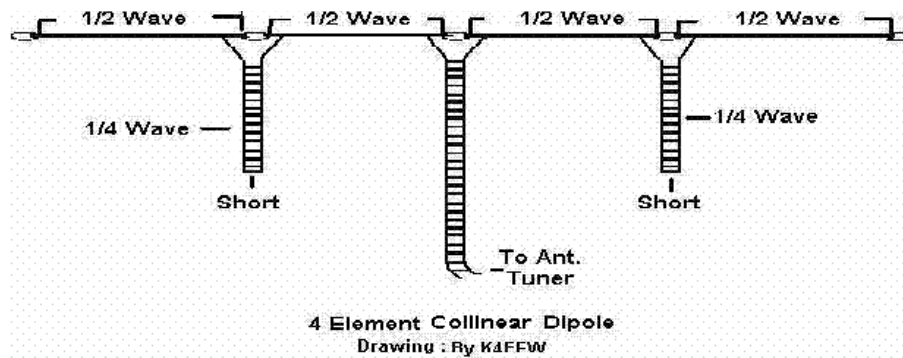

Figure 10.6: 4-Element Collinear Dipole

## 10.10 Coax-Fed Dipoles Operated on Odd Harmonic Frequencies

Antennas fed with 50-ohm coax can be used on other bands for which they are not cut. An 80-meter dipole will have a relatively low SWR and will be resonant at a single frequency on 10 meters and not

much power will be lost in the coax even if operated off resonance. A 40-meter dipole will work the same way on 15 meters. Using coax, a dipole will work on its fundamental frequency and on odd-harmonic frequencies and it is not necessary to use ladder-line. The fundamental frequency is the frequency for which the antenna is a half-wavelength long, and the odd harmonics are 3 times, 5 times, 7 times, etc. the fundamental resonant frequency. A frequency of 21 MHz is 3 times or the third harmonic of 7 MHz, and 28 MHz is the seventh harmonic of 4 MHz.

Antennas operated on their odd harmonics will be resonant a little higher in frequency than exact multiples of their fundamental frequencies. Since the odd harmonic antennas input impedance is higher than it is on its fundamental frequency, many amateurs use a series quarter-wave matching section of 70-ohm coax to give it a better match. The 80 meter inverted-V dipole in use here has a 2:1 SWR on 10 meters indicating it has an impedance of around 100 ohms. However, modeling the antenna for 10 meters shows the resonance to be below 28 MHz, probably because the antennas fundamental resonant frequency is 3920 instead of 4000 kHz. A quarter wave 70-ohm matching section should bring the SWR down to a much lower level.

As said earlier, if you try to use coax with a dipole on its even harmonic frequencies, the feed-point impedance will be very high, the SWR will be extremely high, and the coax will absorb most of the power. In addition, when operating a coax-fed antenna on its even harmonics, the tuner may not be able to provide a match. Operating any antenna on any of its harmonic frequencies, odd or even, will work better if it is fed with ladder-line and a tuner.

This antenna is matched by a quarter-wave 70-ohm series matching section. Three half waves will resonate higher than you would expect because the center half wave doesn't have to contend with end effects. To calculate the length of a three half-wave dipole, divide 1380.6 by the frequency in MHz. Five half waves is found by dividing 2316.6 by the frequency.

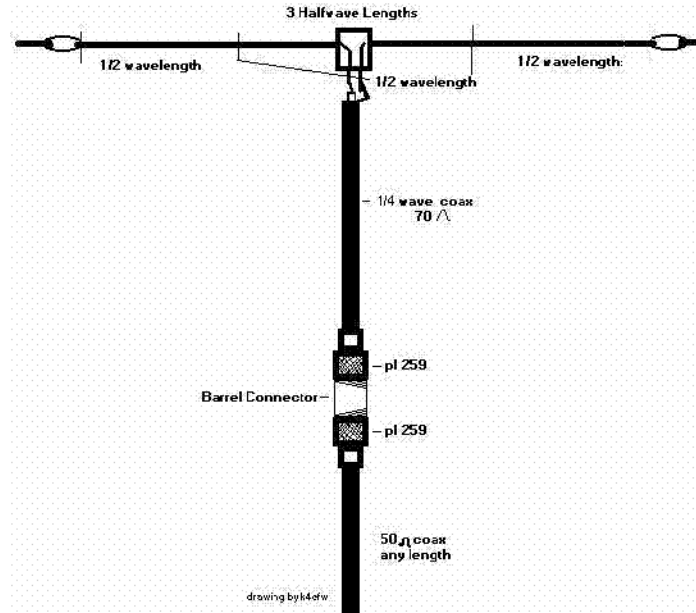

**Figure 10.7: 3 Half-wave Dipole**

To use a 3 half-wave antenna on 15 meters, the 70-ohm matching section needs to be 7 feet 7 inches and the antenna needs to be 64 feet long for a good match. It will be just a little long on 40 meters. When using a 40-meter dipole with a 15-meter quarter-wave matching section, it will still have acceptable SWR on 40 meters.

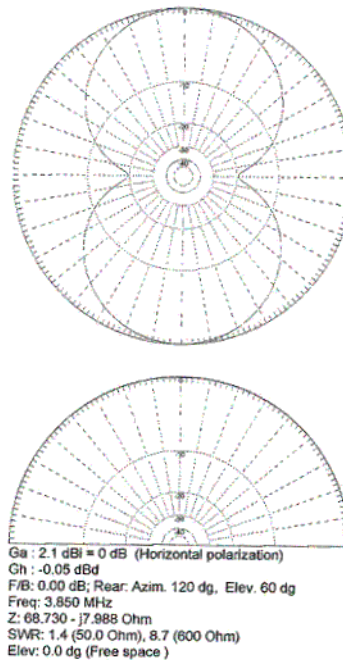

**Figure 10.9: Radiation Pattern of a 15-Meter Three Half-Wave Dipole at 65 Feet**

The pattern shows 6 lobes, 4 major lobes and 2 minor lobes. The vertical radiation pattern shows low angle radiation.

## 10.11 All Band Random Length Dipole

A random length of wire cut into two pieces can be used as a dipole, and it will radiate efficiently. It has to be at least a half-wave length on the lowest band you want to work. It looks the same as the all-band dipole and is the same, except it is not resonant on any band. The random length dipole is being described here to emphasize that the radiating part of an antenna doesn't have to be resonant. Because it will have a feed-point impedance that is unusual, it must be fed with ladder-line a tuner, and a balun. Since you are using a tuner, it can be used on multiple bands. If you make it very long, it can have gain over a dipole. For example, if it is four wavelengths long, it will have 3-dBd gain. As you move to higher bands, the electrical wavelength of the antenna increases, and each higher band will have more gain.

A half-wave antenna radiates perpendicularly to the plane of the wire. As you move to higher bands, this antenna begins to show some gain, and instead of two lobes of radiation, the two lobes split into four lobes and the pattern resembles a 4-leaf clover. As you make the antenna longer, the four lobes move nearer to the ends, the gain increases, and there are minor lobes of radiation between the major lobes. These minor lobes make it possible to work in all directions. The longer the wire, the closer the antenna's major lobes radiate bi-directionally toward its ends.

## 10.12 All Band Center-Fed Random Length Dipole

The problem with using a random length of wire for this antenna is you may find that because of limitations of your tuner, you may not be able to tune a particular length of antenna on some bands. Certain lengths will tune all bands and one of those lengths is 135 feet. That particular length will be nearly resonant on all bands of 80-10 meters. Resonance only makes it easier to tune, but it has no effect on efficiency. A length of 260 feet will tune from 160-10 meters. Lengths of 260 and 135 feet have been used here successfully. Some hams use random lengths of wire without problems. Then some hams have had problems with other random lengths. The ones having the problems solved the tuner problems by changing the length of the dipole wire. If you plan to put up this antenna using a random length of wire, you will need to experiment with various lengths until you find a combination that works.

Tests were performed here using two towers of equal height and spaced 100 feet apart. On one tower, was an 80-meter inverted-V 120 feet long fed directly with coax, and running parallel to it on the other tower was a 135-foot long inverted-V fed with ladder-line and a tuner. At the resonant point of the coax-fed dipole and having tuned the ladder-line fed antenna, it was possible to switch antennas instantly and many hams were asked to look at their "S-meters" while the antennas were switched. All hams that participated in the test said the signals from both antennas were equal. The signals were measured on analog S-meters, not on segmented LCD meters found on most of today's transceivers.

## 10.13A 2-Band Fan Dipole

A 2-band dipole can be constructed by connecting together the feed point two dipoles for even harmonically related bands. It is fed with 50-ohm coax with or without a balun. The best example of this is 80 and 40-meter dipoles connected together. Both dipoles are cut for

half-wave resonance on each of the two bands. They are fed together and the ends of the wires are spread apart. If the ends are close together, there will be interaction between the dipoles. In such an antenna system, both dipoles must be carefully pruned for lowest SWR one band at a time. The lower band will be tuned first since the shorter dipole will not interact with the longer one. Each dipole has a low antenna resistance on the band for which it is resonant. RF energy follows the path of least resistance, and it automatically selects which dipole will receive power. The remaining antenna will have a high impedance. High impedance will block RF. Such an antenna will have a narrower bandwidth than a single band dipole, but close to the resonant frequency of each dipole, a tuner will not be needed. To connect many dipoles for multiple bands is possible, but it is not recommended because multiple wires are prone to interact and it will be impossible to achieve a low SWR on some bands. However, on the two band model, the 40-meter dipole will resonate close to 15 meters, the 80-meter dipole will resonate close to 10 meters, and working four bands with this set-up is possible. Some hams are using this antenna successfully with a tuner on all bands, although the signal on 20 meters suffers somewhat because of high SWR.

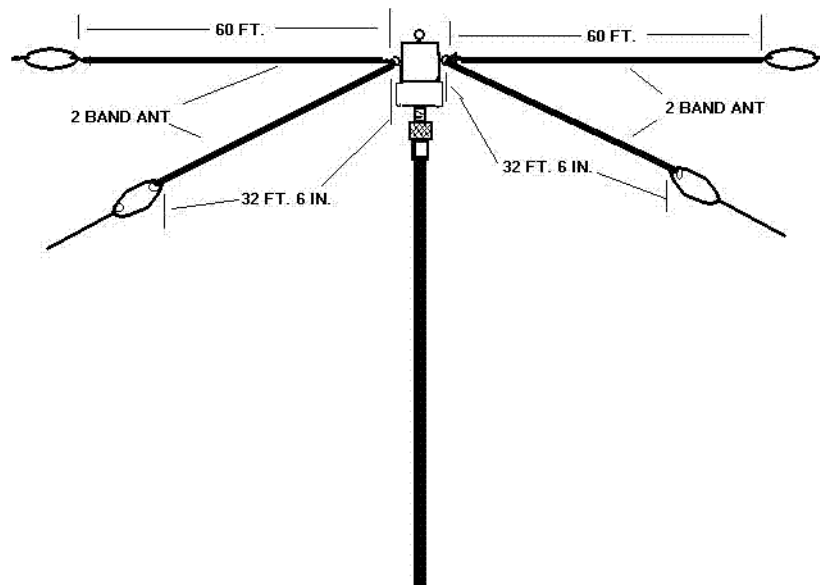

Figure 10.10: Two-Band Fan Dipole for 40 and 75 Meters

## 10.14 Trapped Dipole for 75 and 40 Meters

A trap is constructed from a capacitor and an inductor connected in parallel. It acts as an open switch on the frequency for which it is resonant. A trap is placed on each side of the dipole. For a 75 and 40 meter trapped dipole, the traps must be resonant on 40 meters, and each trap should be placed a quarter wave from the center insulator. The center section between the traps is electrically isolated from the ends of the dipole by the traps on 40 meters, and the center section of the antenna becomes a full-sized half wave resonant dipole for that band. This antenna is fed with 50-ohm coax and an optional balun. Wires connected to the outside of the traps are run to the end insulators and are tuned so the entire antenna resonates on 75 meters. The 75 and 40 meter trapped dipole will be shorter than a 75-meter dipole because the inductor in the 40-meter trap acts as a loading coil on 75 meters. In addition, the ends of the antenna can



be tuned to operate on the 80-meter CW band instead of the 75-meter voice band. Several sets of traps can be inserted at the correct points in the dipole to make a multi-band dipole. Multi-band trapped dipoles are being sold, but in many cases they will require the use of a tuner. If a good match is found at a frequency on some bands, the bandwidth without a tuner will be very narrow. The antenna is only 108 feet long instead of 120 feet because of the

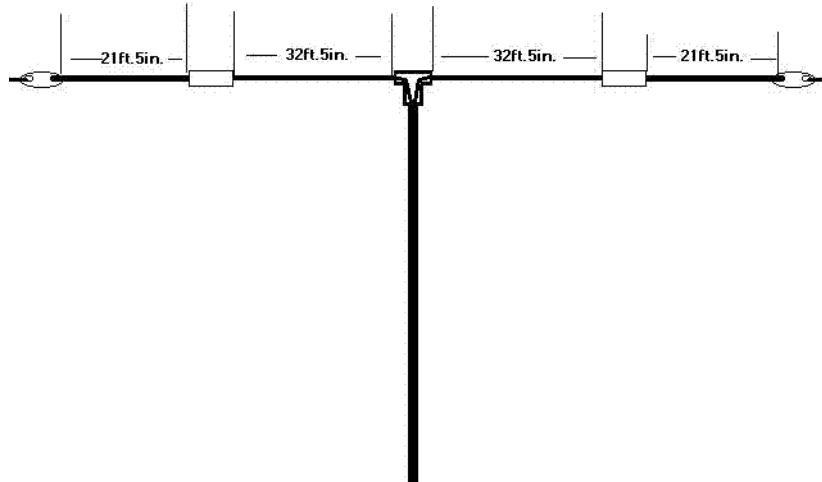

**Figure 10.11: Trapped 75- and 40-Meter Dipole**

loading effect of the traps on 75 meters. These dimensions are for antennas using the traps made by W2AU. If you use other brands of traps, the length of the end wires will have to be adjusted. What you do in that case is make the wire long, measure its resonant frequency on 75 meters, and prune the ends to resonance at your favorite frequency.

## 10.15 The Extended Double Zepp Dipole

An extended double zepp is a long dipole with 3-dBd gain. It is the longest dipole antenna, which will radiate at right angles to the plane of the antenna. To find the overall length of an extended double zepp, divide 1197 by the frequency in MHz. Each leg of the antenna is 0.64 wavelength long and the total length is 1.28 wavelengths. An extended double zepp for 75-meters at 3.8 MHz is 315 feet. Not many amateurs have space for that antenna. The extended double zepp is mostly fed with ladder-line. Another method of matching an extended double zepp is to use tuned lengths of 450-ohm ladder-line as a series matching transformer connected between the 50-ohm coax and the dipole. The length of the matching section of 450-ohm ladder-line can be found by dividing 135 by the frequency in MHz.

## 10.16 The G5RV Dipole

An interesting antenna you can buy that will work somewhat on all high-frequency bands is the so-called G5RV antenna. It is named after the call letters of Louis Varney (SK) who designed it. It is a 102-foot long or three half-wavelength dipole antenna on 20 meters (14.150 MHz), and can be used with a tuner on other bands as well. In his original design, Varney calculated the length to be 102.57 feet, but chose to make it an even 102 feet since a tuner was going to be used with it anyway. It was originally fed through a 34-foot 500-ohm homebrew

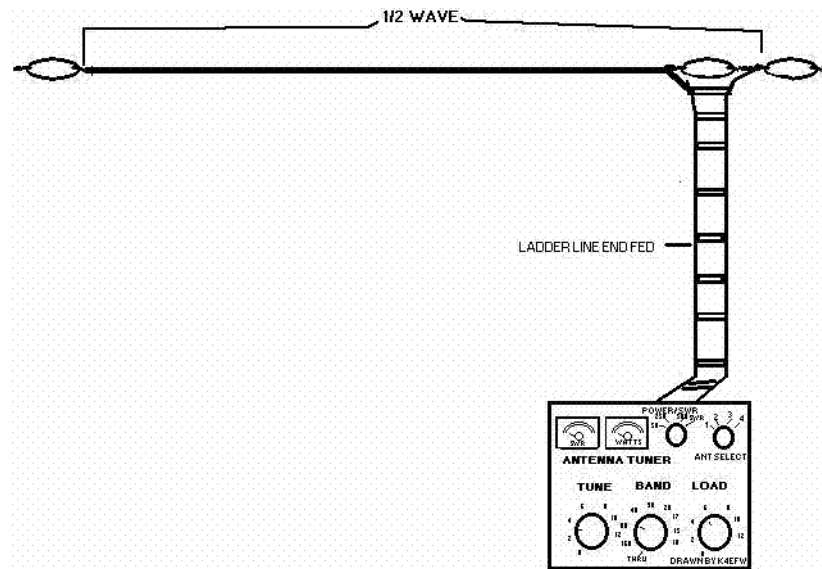

**Figure 10.12: Extended Double Zepp Dipole**

open wire matching section from a 70-ohm coax or parallel conductor feed-line. The 34-foot open wire line is a half wavelength on 20 meters and at the end of a half-wave feed-line, you will see the antenna's impedance repeated regardless of the feed-line impedance. The ladder-line helps partly to match the antenna on the other bands.

The G5RV antenna is around 20 feet short of being a half-wave on 80 meters, and on bands on 20 meters and up, it has theoretical gain. We believe that gain is negated by losses in the coax of the feed system, except for 20 meters. At the frequency of the best match, commercially made models of the G5RV are said to have a 1.8:1 SWR on 80 meters. Where the coax joins the open wire, Varney recommended using a choke made of 8 to 10 turns of coax. He advised against using a balun, because, as he says SWR of 2:1 or higher may cause the balun to heat and possibly burn out. The SWR will be moderately high or high on bands other than 20 meters. Varney recommends using the lowest loss coax available and as short a run as practical because of feed-line losses caused by high SWR. This recommendation is very important today, as it was when Varney designed it. Some G5RV antennas put out decent signals and some others have relatively weak signals. Without further investigating, the only way to explain this is that some are using lossy coax and baluns while others are not, and the height above ground may play a part in how well it works.

The G5RV antennas being made today use small diameter 50-ohm coax, 450-ohm ladder-line, and a balun between the ladder-line and the coax, contrary to Varney's suggestions. There are several variations of the G5RV antenna being sold today because many believe they can improve the original design. If you use a G5RV antenna, a tuner will be required.

The G5RV shown in *Figure 10.13: G5RV Dipole* on page 39 is close to the original version of the antenna. This one pictured below is from an old article that K4EFW found somewhere. It is like the one he used. As you can see, it uses 300-ohm TV ribbon. The length of the parallel TV ribbon is 36 feet, but modern designs of this antenna use 34 feet of 450-ohm ladder-line. All these variations work equally well when they are used with a tuner. It is shown in the inverted-V configuration but it could be put up in the flattop configuration as is, with no modification.

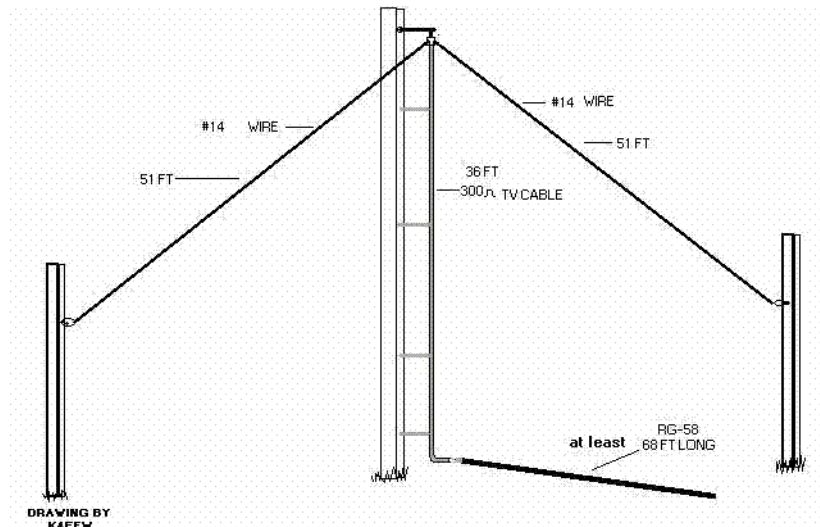

Figure 10.13: G5RV Dipole

Jeff, AI8H, in Oxford, Georgia, had a pair of G5RV dipoles oriented in different directions. Recently he put up a 75-meter half-wave inverted-V. Being able to switch antennas, he ran A-B tests on 3902 kHz and the inverted-V was 10 dB stronger than the first G5RV and 15 dB stronger than the other one. Now if we are saying the stronger signal is 40 dB over S-9 and the weaker signal is 25-30 dB over S-9, no one will notice the difference. Only under marginal band conditions will the difference be important. In addition, the G5RV antenna will work better on the other bands.

## 10.17 Off-Center Fed Dipoles

A long dipole consisting of multiples of equal half-wave segments is normally fed in the center using ladder-line. Dipoles do not necessarily have to be fed in the center. They can be fed in the center of any one of these half-wave segments, even fed off-center. A fair match will occur if coax is used.

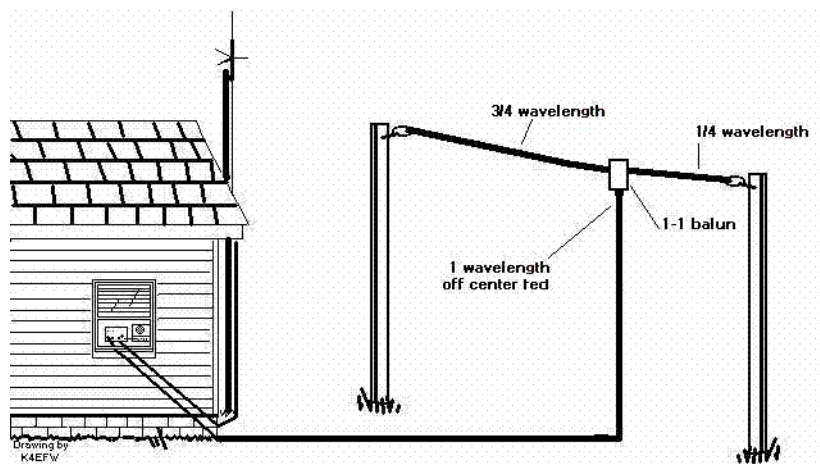

Figure 10.14: One Wavelength Off-Center Fed Dipole

The dipole shown in *Figure 10.14: One Wavelength Off-Center Fed Dipole* on page 39 is a one-wavelength dipole. It is nothing but two half waves end to end. It is being fed in the center of one half-wave segment or a quarter wave from one end. It is possible to make it any number of half waves, and if it is fed a quarter wave from one end, it will have a fair match. The way it is shown above is an example of how to feed an antenna with even multiples of a half wave using coax. A 2:1 or 4:1 balun will improve the match on longer versions.

The windom antenna is another example of an off-center fed antenna. The original windom was fed off center with a single wire. The other side of the transmitter was connected to ground. The feed-point impedance at the transmitter was reported to be 500 ohms on all bands. The antenna was designed by William L. Everett and J.F. Byrne at Ohio State University. W8GZ, whose last name was Windom, described the antenna in the September 1929 issue of *QST*.

A lot of research concerning the modern variations of the Windom antennas has been done, including the ones described by Fritzel, K4ABT, W4RNL, The Carolina Windom, and ON4BAA. The main differences in these variations are the slight differences in the position of the feed-point and the impedance of the baluns used for matching. The Windoms are sensitive to the height over ground, meaning the height above ground affects the SWR. The offset position of the feed-point will also determine the feed-point impedance. The one sold by K4ABT is a variation of the Fritzel antenna, and the one sold by Radio Works, The Carolina Windom, (shown in *Figure 10.15: Windom Dipole* on page 41) claims it has a vertical radiator.

There are two variations of Windoms, both claiming they have vertical radiators, The Carolina Windom and the one previously marketed by W4COX have two pieces of transmission line in series. The upper piece is connected to the dipole, and the lower piece is connected to the transmitter. The feed-point of the dipole is placed off center. In The Carolina Windom being marketed today, the upper transmission line is coax. The one made by W4COX had the upper piece made from ladder-line, but in either case, the principle is the same. The two pieces are connected together through a line isolator, a type of balun. The line isolator keeps the lower piece of transmission line from radiating. Because the antenna is fed off-center, the marketers of The Carolina Windom claims it causes an unbalance of current in the upper piece of transmission line. This is doubtful because there is a balun at the feed-point, which should prevent the feed-line attached there from radiating. The main difference between The Carolina Windom and the one sold by W4COX is that a 4:1 transformer is between the coax and the ladder-line, and a 1:1 line isolator is between the upper and lower coax cables. Both variations of this antenna show low SWR on several bands, but a tuner is used to match it.

Another unique variation of the Windom dipole is the Fritzel antenna, named after its inventor and manufacturer, Dr. Fritz Spillenger (SK), a German ham, call sign DJ2KY. Alpha Delta is now selling an almost exact duplicate of the original Fritzel antenna. Alpha Delta calls it an OCF antenna and it is made by Buckmaster Antennas. There are two models of the Alpha Delta antenna: one for low power and one for high power, the power rating of the balun being the limiting factor. The Fritzel's short side is 0.18 wavelength long and its long side is 0.32 wavelength long. It is fed with coax and a 6:1 balun. Theoretically, the feed point impedance is 300 ohms, and the balun provides a 50 to 300 ohm impedance transformation. Modeling the antenna on its lowest resonant frequency at 35 feet, it shows about 120 ohms impedance. The original Fritzel antenna being used by K4LMS reportedly will work all bands with a tuner, but it will work 40, 20, 17, 12, and 10 meters without a tuner with an acceptable SWR. The

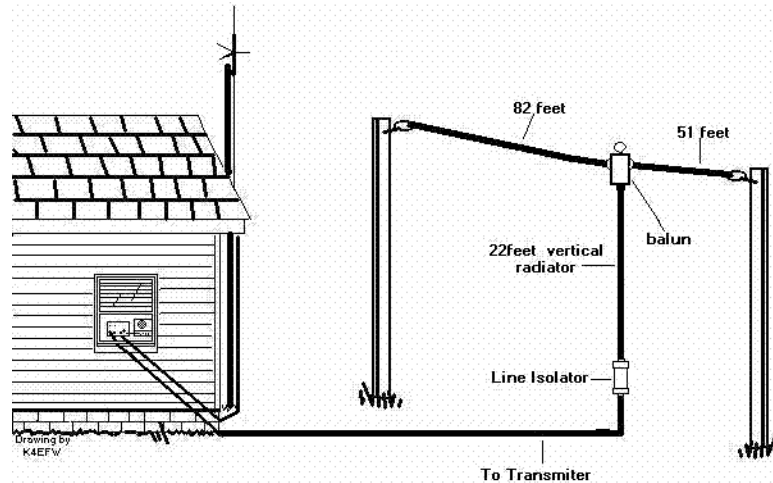

**Figure 10.15: Windom Dipole**

Windom being sold by K4ABT uses a 4:1 balun and the feed-point is at a slightly different location. That one is shown in *Figure 10.16: Windom Dipole (Fritzel Type)*.

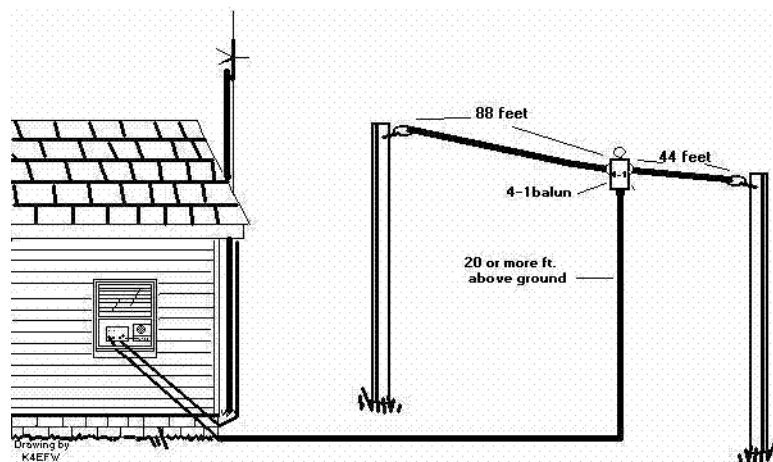

**Figure 10.16: Windom Dipole (Fritzel Type)**

The difference between the Windom antenna sold by K4ABT and the original Fritzel is the difference in the offset of the feed-point. Since the K4ABT version uses a 4:1 balun, it appears his is fed at the 200-ohm point, and the original Fritzel is fed at the 300-ohm point. On any resonant dipole, the lowest feed-point impedance is found at the center. As you place the feed-point offset toward either end, the impedance gets higher. The highest feed-point impedance occurs at the end of the dipole.

# 11.

## ***End-Fed Antennas***

### **11.1 End-Fed Zepp**

A half-wave resonant antenna can be fed from its end. When fed this way, it is also known as an end-fed zepp. An end-fed zepp will work on its fundamental frequency and on odd and even harmonic frequencies. The name “Zepp” goes back to the days of dirigibles or Zeppelins, which used trailing wire antennas that had to be fed at one end. The end of a half-wave antenna has very high impedance, and an antenna fed this way is said to be voltage fed. Feeding a half-wave resonant dipole in the center means it is current fed. The normal way of feeding the end-fed antenna is with ladder-line. One side of the ladder-line is connected to one end of the antenna and the other side of the ladder-line is connected to nothing. To secure the unconnected side of the ladder-line, it is connected to a short wire running between two insulators. Since the antenna is connected at its high impedance point, no current flows into an antenna, but there will be a large current in the center of this antenna. No current flows from the open side of the feed-line because it is at a zero current point. (See *Figure 11.1: End-Fed Zepp* on page 43.)

The end-fed zepp can be matched by cutting the ladder-line to a quarter wavelength with the bottom end of the ladder-line shorted. A certain distance above the short is a 50-ohm feed-point and it can be fed directly with coax. MFJ is marketing antennas of this type made for single bands, and they are selling the parts separately so you can build your own. You will have to find the 50-ohm point by trial and error. This method of feed makes it a single band antenna.

### **11.2 End-Fed Random Length Antenna**

*Figure 11.2: End-Fed Random length or Long Wire Antenna* on page 43 shows another end-fed antenna made from a random length of wire connected to the back of the tuner. The wire then exits the shack and goes to a high support where it then runs horizontally to another high support. The tuner's groundside must be connected to a good RF ground, since a poor ground causes high losses. This antenna is commonly called a “long wire.” Since the end of the antenna comes in the shack, you will be exposed to high levels of RF. In addition, this type of installation may cause RF to be picked up in the microphone, noted by distortion. The

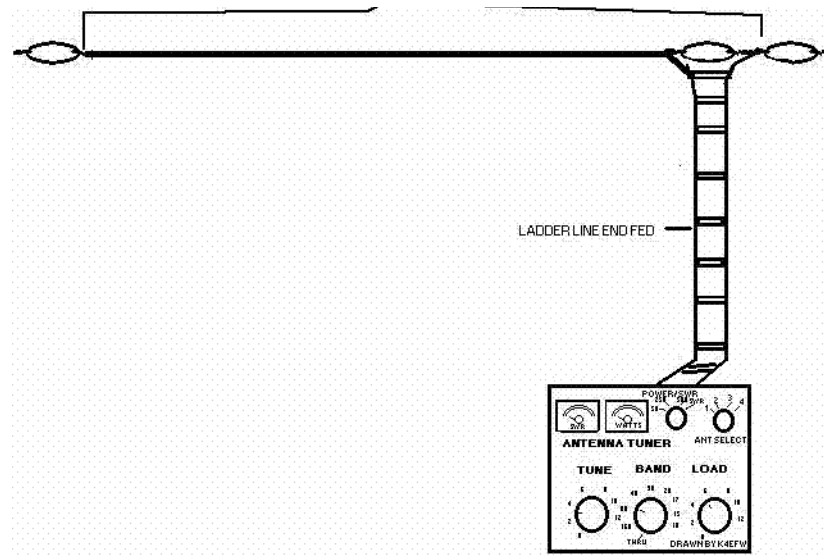

Figure 11.1: End-Fed Zepp

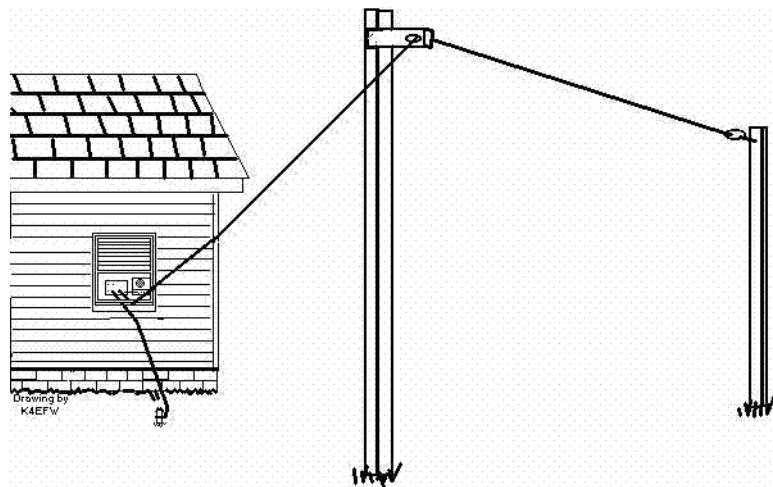

Figure 11.2: End-Fed Random length or Long Wire Antenna

feed-point of the long wire being connected directly at the output of the tuner can have an impedance of a few ohms to a thousand ohms depending on the antennas length. If the wire is cut to a multiple of a half wave at the lowest frequency, the system will be efficient since it is fed at a voltage point and very little current flows into the ground. This antenna is really a variation of an inverted-L fed directly without a feed-line from the tuner.

# 12.

## *The Half Sloper*

The half sloper shown in *Figure 12.1: Half-Sloper Antenna* on page 45 is an antenna that is hard to categorize, since it is not a sloping dipole and it is not a vertical. The half sloper is half of a sloping dipole. To make one of these antennas, cut a quarter-wave radiator by dividing 234 by the frequency in MHz and tie an insulator to both ends. One insulator is tied near the top of a tower and the radiator wire is run down toward the ground. Coax is split into its center conductor and shield, and it connects across the insulator at the tower. The center conductor of the coax is tied to the quarter wave radiator and the shield is grounded to the tower. This means the tower is acting as the missing half of the dipole. It is a difficult antenna to get a good match because the height above ground of the feed-point and the angle of the slope affect the impedance. Some users of this antenna say to mount the feed-point at 45 feet up on the tower and have a beam antenna on the tower above the feed-point to use as a counterpoise. Other users say you must find the 50-ohm point on the tower, which is a tedious task. It has also been said, "Some installations work super, while others do not work well at all." The half-sloper is used almost exclusively on 80 and 160 meters. The Alpha-Delta half sloper was tried here and its performance was disappointing. The signal from it was down a least 10 dB below a dipole and the SWR wasnt low enough. The half sloper is mostly vertically polarized and it is directional toward the slope.



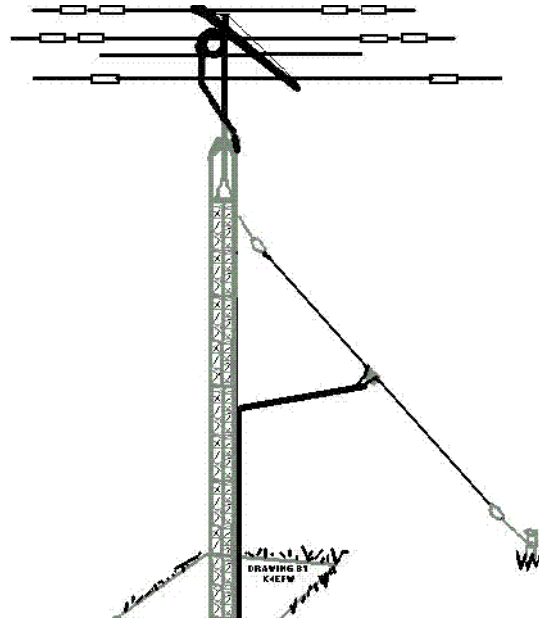

Figure 12.1: Half-Sloper Antenna

# 13.

## *Vertical Antennas*

### 13.1 Why Verticals Are Used

Vertical antennas have the radiator mounted at right angles to the earth. The vertical is used whenever you desire to radiate your signals in all directions at a low angle. Low angle radiation is needed to work DX effectively. Radio waves traveling to the ionosphere where they are reflected need to hit the ionosphere at a point near the horizon in order to reflect farther around the curvature of the earth. In order to get a dipole to radiate a strong signal at low angles, it has to be more than a wavelength above ground. A low dipole is not particularly a good DX antenna for 80 and 160 meters. However, the average dipole at modest heights will outperform any ground-mounted vertical having a poor ground system. Vertical antennas work very well at low frequencies such as the broadcast band, but the ground losses increase as we move higher and higher in frequency (Refer to *Section 5.2 Ground-Wave Propagation* concerning ground-wave propagation). It is very difficult to get a good ground for a ground-mounted vertical unless you live next to salt water. Vertical antennas, because they are unbalanced antennas, do not need baluns. They are normally fed with coax.

If a ground mounted, quarter-wave vertical is all you can put up at your location (QTH), then use it. However, it will be a mistake to put up this antenna if you are not be able to have a ground radial system and are able to put up a dipole. Most ground mounted quarter-wave verticals manufactured today are trapped in order to work multiple bands.

The ground-mounted vertical also needs to be put out in the clear away from RF absorbing objects. These facts do not apply to half-wave verticals, which are in themselves different animals, nor do they apply to high quarter-wave verticals using elevated radials.

The approximate length of a full-sized resonant quarter wave vertical can be found by dividing 234 by the frequency in MHz. Note: 234 is half of 468, the number we used to calculate the length of a half-wave antenna. The actual length for resonance may be a little different from what you calculate, because of the diameter of the vertical element. Trapped verticals are physically short of a quarter wave in length because the traps load them. The vertical is fed at one end at the bottom where it is insulated from the ground. The center conductor of the coax connects to the vertical element and the shield is connected to the ground system.

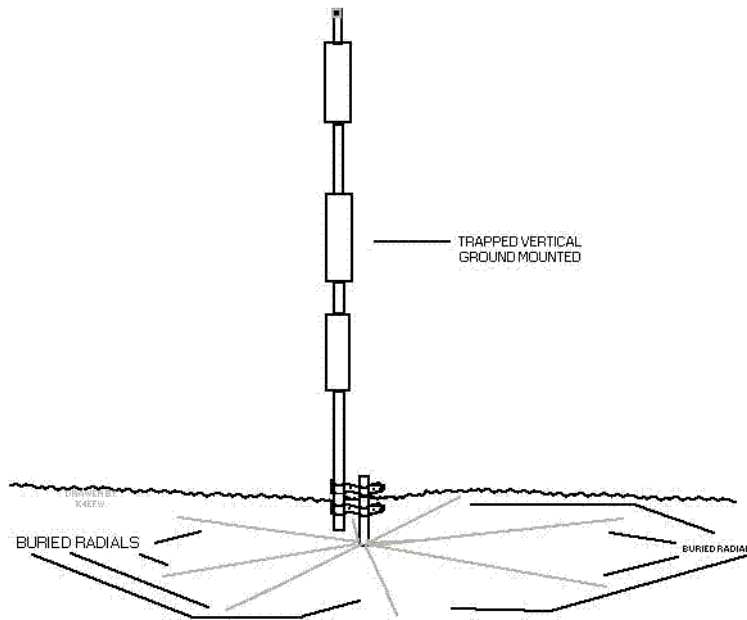

Figure 13.1: Ground Mounted Trapped Vertical

## 13.2 Disadvantages of Using Quarter-Wave Verticals

The most obvious disadvantage of using any vertical antenna is on 80 meters it has less than optimum high-angle radiation needed to work stations within a few hundred miles. Ground-mounted quarter-wave verticals use a ground system for the other half of the antenna and the ground system losses can be very high. The ground wave signal should eventually radiate in space at angles at the horizon, but since there are very high losses in the ground wave at amateur frequencies, a ground-mounted vertical has almost no signal down near the horizon. At angles below 10 degrees, the signal will be greatly attenuated.

A ground-mounted quarter-wave vertical with an ideal ground should have an impedance of 35 ohms resistive. If you were to measure its impedance, and it measures 60 ohms resistive on an antenna analyzer, it means it has a loss resistance of 25 ohms. Moreover, that loss resistance is mostly in the ground system. Under these conditions, only 58 percent of the power will radiate as RF, although you will have a 1.3:1 SWR. 42 percent of the power will be turned into heat by the loss resistance. With the feed-point being at ground level, some more loss comes from the radiated wave being absorbed by power lines, trees, and buildings with its associated wiring. That loss does not show up in antenna analyzer measurements.

The best ground system for a ground-mounted vertical is 120 wires, called “radials,” radiating from the feed-point like the spokes of a wheel. These radials need to be a quarter wave long. At the feed-point, the radials are bonded together and are fed from the shield side of a coax cable. Not many amateurs have the resources to build such a ground system. Many short radials will be more effective than a few long ones. When using a ground mounted vertical, many hams drive an 8-ft. ground rod into the earth for their ground system. The ground losses are very high in that case. Using a ground rod for the ground system of a vertical antenna confirms the old adage: “Verticals radiate poorly in all directions.”

To eliminate ground losses, you can use an elevated quarter-wave vertical with an elevated ground system called a “ground plane.” The ground plane vertical, as it is called, needs to be mounted high enough to prevent the return path from coming back through the earth ground. Ground plane verticals need to be mounted above nearby objects that absorb RF. They will be nearly 100% efficient if they are high enough. The ground plane consists of two or more radials, but most ground planes have three or four. The ground plane radials do not have to be resonant, but should be at least a quarter wave long. An elevated ground-plane vertical will be more effective for working DX than a dipole.

### 13.3 Long and Short Verticals

Verticals can be less than a quarter wave in length. They can be loaded by coils or linear loading sections or a short vertical can be fed directly with a tuning unit at the feed-point. The loss resistance in a short vertical may be appreciable. Since the radiation resistance is very low at the feed-point of a short vertical, the current at the feed-point will be very high. The more current that flows into loss resistance, the higher the loss will be. Any coils used in the tuning unit and for loading should be made of as heavy a conductor as possible, since these can cause appreciable loss when the current is high. This is also true for the ground system. The loss described here is called “I squared R loss”, which means the loss in watts is found by multiplying the current times itself and then multiplying that answer by the loss resistance. That means if the current into a lossy antenna system is doubled, the power lost in watts is increased four times. Making a vertical very short and tuning it to resonance with an inductor will also result in an antenna with a very narrow bandwidth.

A more subtle loss of energy in very short vertical antennas is coronal discharge from the tip end of the vertical. Corona occurs when the voltage is very high at the end and electrons flow out into the air. This can be visible at night if the transmitter power is high and you are at a high altitude. Power is lost from the antenna when corona is produced because corona is a form of light and light is another form of energy.

In 1973 while we were working for radio station WWNC in Asheville, North Carolina, a trapped vertical for 10 through 80 meters was erected. The length of the antenna was only about 25 feet. A loading coil near the top made it resonant on 75 meters. The ground system was the metal body of a 75-foot long mobile home. Fair reports were received from this set-up. The reports were not bad because of our having a good ground. One night, while working 75 meter SSB, one of the neighbors came over and said, “You’re tearing up my TV.” Checking all of the inside connections proved they were tight. Our wife keyed up the transmitter while we made a trip to the antenna to check the connection there. Before arriving there, looking up, we saw blue fire coming off the end of the vertical. The corona was responsible for the television interference ( TVI ). It was visible because Asheville is at a relatively high altitude and the transmitter was running 700 watts. An inverted-V was put up, the TVI disappeared, and better signal reports were received.

You can realize up to a 1.5 dBd gain from a vertical antenna by making it longer than a quarter wave, but there is a limit to how long to make it and still get low angle radiation. That limit is 5/8th-wave. To find the length of a 5/8th-wave vertical, divide 585 by the frequency in MHz. For example, to calculate the length of a 5/8th-wave vertical for 20 meters (14.000 MHz) divide 585 by 14.0. It equals 41.786 feet or approximately 41 feet 9.5 inches. A tuning unit will be needed at the feed-point of this antenna, as the impedance of a 5/8th-wave antenna is

low and high current will flow into it. A tuning unit will usually have enough bandwidth to cover the entire band on each band of 20 meters and higher. A tuning unit is also called a matching network. It is similar to an antenna tuner, but has fixed inductors and capacitors. Tuning units for 80- and 160-meter verticals will cover only a portion of the bands. Outside the bandwidth limits of the tuning unit, you can use the tuner at the transmitter end. Radials or ground planes are needed for a 5/8th-wave vertical and they need to be a quarter wave long.

The impedance of a half-wave antenna is high if fed at its end. An end-fed half-wave vertical will have a small amount of gain over a quarter-wave vertical. This antenna does not have the ground losses a quarter-wave vertical has because it is fed at a high impedance point and the current flowing into the ground is negligible. Commercially made resonant half-wave trapped verticals now on the market are end fed at the bottom. A built-in matching network is found at the base, and several very short radials are mounted below the feed-point to de-couple RF from the feed-line. These antennas should be mounted as high as possible away from RF absorbing objects. Because the ground losses are lower, the half-wave vertical will outperform a quarter-wave vertical by several dB and in many cases many dB.

## 13.4 Unscientific Observations of Verticals

At our home, an old Hy-Gain trapped quarter-wave vertical for 40-10 meters was erected in 1961. It was mounted on the roof and had two quarter-wave radials for each band. It worked, but it was never compared to another antenna. It gave the impression it was a mediocre antenna. Other antennas replaced it.

One time in 1964, a grounded 60-ft tower was shunt fed as a vertical on 75 meters. Without having any radials, the transmitted signal was 10 dB weaker on this vertical 650 miles away in New York than on the inverted-V.

In 1969, a 4-band trapped vertical was put up on the top of a 60-ft tower. A 15-meter 4-element yagi under it was used for the ground plane. It was probably the best vertical installation we ever tried. It was good because it was high and in the clear and the 15-meter yagi made a good ground plane.

While we are on 80 meters, a ham 200 miles away frequently joins in the roundtable. He uses a trapped quarter wave vertical with a chain link fence as the ground. Several of the others are also 200 miles away run the same power. His signal is 10 to 20 dB below everyone else's on the frequency. It is good there are no interfering signals or noise or he will not be copied.

Another ham uses a Hy-Gain Hy Tower vertical with 3 ground rods as the ground system. According to our S-meter, his signal is 40 dB down below those of the other guys.

Charlie, AD5TH, works 40 meters using a Hustler 5-BTV vertical ground mounted with 72 quarter-wave radials. He has an outstanding signal for a ground-mounted vertical. His installation is out in the clear away from RF absorbing objects. He says, because of antenna restrictions at his location, it is the only antenna he can put up.

Another ham friend, N2HGL, has both a dipole and a half-wave trapped vertical on 40 meters. At a location 160 miles away, he is 10 dB stronger on the dipole, but he is equal in strength on both antennas in Indiana 600 miles away. This comparison shows the superiority of the half

wave vertical over the quarter-wave one because his signal with the half-wave vertical was equal to his signal from the dipole. If he were using a quarter wave vertical, we would expect his signal would be better on the dipole in Indiana. It also demonstrates the superiority of a dipole over a vertical for working short distances.

Bill, W4ZQL, runs a ground-mounted SteppIR vertical. He lives beside a salt-water river in Florida that he uses for a ground. He puts out a very good signal on 40 meters. No ground losses!

## 13.5 The Inverted-L Vertical

The inverted-L antenna is a wire vertical antenna with part of the top end bent horizontally. It resembles an “L” turned upside down. The inverted-L is used to reduce the height required by a vertical and still keep the antenna resonant and full sized. It is fed at the end at ground level the same way a ground mounted vertical is fed, and all the losses we described for a ground-mounted vertical apply here. Some current flows in the horizontal part of the inverted-L and for that reason, it has both strong vertical and weaker horizontal polarization. If you make it a half-wave antenna, you won't need a good ground because negligible current flows into the ground. A half-wave inverted-L antenna needs to be fed with 50-ohm coax and a tuning unit.

An inverted L for 160 meters is usually made of wire one-quarter wavelength long or about 127 feet. It runs vertically from near ground level to the top of a support, perhaps 60 or 70 feet. Then the end runs horizontally and is tied to a nearby support. The antenna is coax fed at ground level between the vertical section and ground system across some type of insulator. A matching network at the feed-point will be required to match it if the impedance is not equal to 50 ohms.

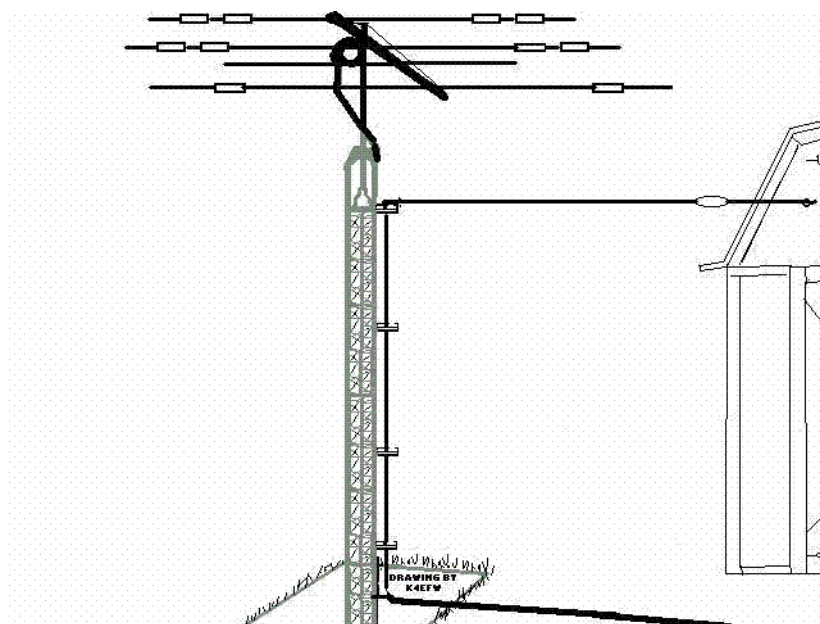

Figure 13.2: Inverted-L

The picture shows an inverted-L running up the side of a tower. The feed-point is at ground level with the center conductor of the coax attached to the bottom end of the wire. The coax shield connects to a ground system of radials. The total length of wire used in this antenna is half of what is needed for a dipole since the other half of the antenna is the radial ground system. The inverted-L is used mostly on 160 meters, but some have built them for 80 meters. The inverted-L antenna can also be cut for a half-wave to reduce ground losses.

## 13.6 Vertical Mobile Antennas

We have heard many good signals from mobiles, many being stronger than those from hams using ground mounted quarter-wave verticals. The mobile antenna, being so short, has a large capacitive reactance. A coil is inserted in the antenna to provide an equal amount of inductive reactance to make it resonant. As we said in the paragraph on short verticals, a coil of this type, carrying a large amount of antenna current, causes some loss resistance in the system. To reduce losses in the coil, wind it with a conductor as large as practical. (That's exactly what some mobile antenna manufacturers have done.) The sources of loss in mobile antennas are in the coil losses, losses in the conductors making up the radiating part of the antenna, corona discharge, and the ground loss from the vehicle on which it's mounted. However, because of the large amount of metal in the body of the vehicle, the ground losses are not as high as the losses from ordinary ground mounted verticals. Matching transformers are now available that step down the impedance of 50-ohm coax to the very low impedance of the loaded vertical. Good advice is to use the transformers rather than to rely on the internal tuner of the transceiver.

Some low priced single-band mobile antennas are constructed by using a polymer shaft and a small gauge wire encapsulated in polymer material running beside the shaft. The loading coil made of the same wire is also encapsulated in the polymer. The small wire, because of its size and because it carries a large RF current, will lose a lot of power by becoming hot. This type of mobile antenna is rated for 200 watts. If the wire didn't get hot, there would be no power limit.

All mobile antennas have corona loss and for such, there is no remedy. Most amateurs, because they can't see it, don't believe it's there. Corona will not be visible unless you run high power and it is dark.

Ground losses from the vehicle's body diminish with increasing vehicle size. This is why 18-wheeler hams have such big mobile signals. To diminish the ground losses on any mobile installation, you should use as large a conductor as possible to bond the coax shield to the vehicle body. All metal parts of the vehicle's body, frame, and drive system need to be bonded together with heavy ground straps. To make the mobile antenna system more efficient, use an antenna with an adjustable inductor and use as long a "stinger" as practical above the coil. You will increase the radiation resistance by using a longer stinger, and then the loss will be less because you will require less coil inductance. The ratio of radiation resistance to loss resistance becomes larger by raising the radiation resistance and reducing the loss resistance. As we said earlier, the efficiency of any antenna system is found from the ratio of radiation resistance to total resistance, or radiation resistance divided by total resistance times 100%. The total resistance is equal to all the loss resistances plus the radiation resistance.

The latest development in HF mobile antennas is motor driven variable inductors. These antennas are known as "screwdriver antennas." The name refers to the electric screwdriver

motors used to vary the inductance. A control cable is run from the motor to a switch at the operators position so it can be tuned from the operators seat in the front of the vehicle. Because a mobile antenna has a very narrow bandwidth, you will have to tune it often as you move frequency (QSY). It hasnt been many years since we had to get out of the vehicle to make inductor changes or make changes in the length of the stinger when the frequency was changed.

Mobile antennas for 20 through 10 meters do not require the care in installation that is needed for 160, 80, and 40 meters because the length of a mobile antenna becomes closer to a quarter wave as you move to higher bands. The radiation resistance increases on each higher band. While moving to higher bands, less inductance is needed to tune the antenna, and that lowers the loss resistance. A 96-inch mobile whip is just a couple of inches short of being a quarter wavelength on 10 meters and a loading coil is not needed there. The band that has the least mobile antenna efficiency is 160 meters. If you reach a radiation efficiency of 2% on 160 meters on your mobile installation, you will be doing well.

Below is some information concerning mobile antennas, which was received in an email. There was a 75-meter mobile “shoot-out” in California. (A shoot-out is an event where a group of hams gets together and compares signals radiated from various antennas.) Supposedly, equal power was applied to each antenna under test. Apparently, some type of field strength meter was used. A screwdriver antenna and a bug catcher, both with top hats, were used as the standard by which other antennas were compared because they put out equal signals. The other antennas are measured in how many dB they were below the standard. Here are the results of that test, and because it is hearsay, the accuracy of these figures is not guaranteed, but they do compare to what we have observed.

**Table 13.1: Antenna Shoot Out Results**

Screwdriver/bug catcher with top hats	0 dB reference
Screwdriver/bugcatcher without top hats	-3dB -50%
Hustler	-7 dB -80%
Outbacker	-9 dB -88%
Hamstick	-12 dB -94%
Whip with autotuner	-14 dB -96%.

The efficiency of the best 75-meter mobile antenna is from 5% to 10%. In using the best mobile antenna on 75 meters, a 100-Watt mobile rig will radiate 10 Watts at most. This means that a Hamstick being fed with 100 Watts will radiate only 0.6 watts, which is 6% of 10 Watts. Ninety-nine and four tenths Watts will be converted to heat. The person sending this information said it was published on the Internet in some news group. Again with good band conditions, it is amazing how little signal can be used to communicate.

The things that increase the efficiency of mobile antennas are:



- Place the loading coil about half way from the feed-point to the antenna tip. Efficiency decreases if you put the coil above or below this point
- Mount the antenna as high up on the vehicle as possible. This reduces the ground losses because it reduces the capacitance of the antenna to ground
- Use a loading coil with a Q as high as possible. See the ARRL Handbook for a discussion of coil Q
- Make the antenna as long as possible. Note: long antennas are prone to strike tree limbs and bridge overpasses
- Increase the size of the mast between the loading coil and feed-point
- Put a capacity hat above the loading coil. The capacity hat reduces the number of coil turns needed to resonate the antenna
- Make the coil with as large a diameter wire possible. This decreases the coil loss, which is a large part of the total loss of a mobile antenna.

Any changes made in the antenna system that raises the radiation resistance will increase the efficiency

# 14.

## *One-Wavelength Single Loop Antennas*

### 14.1 The Horizontally Oriented Loop

To calculate the length in feet of any one-wavelength loop, divide 1005 by the frequency in MHz. Horizontally oriented one-wavelength loop antennas have become very popular on 160, 80, and 40 meters and it is one type of NVIS antenna. (NVIS stands for “near vertical incidence skywave” because of its high angle radiation pattern.) It is claimed by its users that the loop antenna is quieter than other antennas. This is because it doesn't pick up the noise from power lines, thunderstorms, etc., coming in at low angles. These antennas radiate on their fundamental frequencies with a broad pattern straight up to put a strong signal for nearby contacts. Recently published articles on this type of antenna have called them “cloud warmers.” There are other types of antennas called NVIS antennas other than loops. They are dipoles at low heights or dipoles with parasitic reflectors placed under them to cause the signal to radiate mostly straight up. The NVIS antennas have an advantage in working nearby stations because you don't get the static noise and interference from far distances. They are definitely not DX antennas. An article on NVIS antennas appears in the December 2005 QST.

On their fundamental frequencies, horizontally oriented loops take up half the horizontal distance as a half wave antenna for that band. Loops are two-dimensional antennas having depth as well as breadth. There are two loop configurations: The square loop and the triangle loop. Some hams have pulled the loops out in irregular shapes to fit where the supports are located. The only advantage in using a rectangular loop instead of a square loop is to take up less horizontal space. This is true because the gain of a rectangular loop is diminished below a square loop. The area enclosed by the perimeter of the loop determines the gain of a loop. A circular loop has the most enclosed area, but it requires an infinite number of supports. The gain of a loop comes from the loop having two maximum current points separated by a distance of one-quarter wavelength. From here on we will call a horizontally oriented loop a horizontal loop.

We also modeled the gain of the horizontal loop for the 80-meter band over real ground. The maximum gain occurs with the loop at 7 meters or about 25 feet above ground. Mind you, this gain is straight up from the loop. At that height, its gain is about 9.25 dBi and that equates to about 7 dBd in free space. The gain of the loop diminishes slightly as the antenna is raised.

The feed-point radiation resistance at 7 meters height is 35 ohms resistive and 0.0 ohms reactance and you do not need a matching section of 70-ohm coax. At a height of 10 meters or about 33 feet, the radiation resistance rises to 63.5 ohms. There the SWR will be 1.27:1, if it is fed directly with 50-ohm coax. At 15 meters or about 50 feet, the radiation resistance rises to 118 ohms and a 70-ohm matching section will be in order. The gain drops to a little less than 7 dBi at that height. These figures may or may not be applicable to your QTH, because your soil conductivity may be different from the soil we used to model it. As you can see from the above numbers, the feed-point resistance rises as the loop is raised.

The horizontal loops also are used on their harmonic frequencies. The loop with more gain and a superior pattern is a two-wavelength loop. An 80-meter loop is a two-wavelength loop on 40 meters. The two-wavelength loop has a lower angle of radiation, but is a very large antenna for 80 meters. At 3800 kHz it has a perimeter of about 530 feet. A two-wavelength loop is not an NVIS antenna. Using coax with a tuner is not an ideal way for working a loop on its harmonic frequencies. This is because of the high SWR in the coax on some bands will cause high loss. For example, an 80-meter loop fed on 40 meters will have an SWR of 8:1 and the SWR on 20 meters will be 49.5:1. There will be some hams who will say they get satisfactory results this way, however theory suggests they will have a stronger signal if they use a ladder-line because ladder-line has less loss. Feeding a loop antenna with ladder-line makes more sense when working a loop antenna on harmonic frequencies.

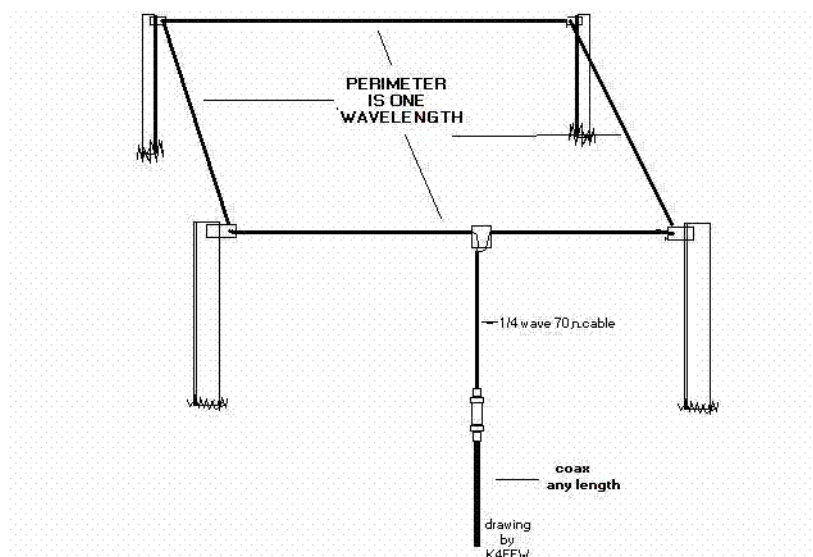

**Figure 14.1: One Wavelength Horizontal Loop**

To realize maximum gain, make the square and triangle have equal sides. When the sides are equal, the loop has maximum enclosed area for whatever configuration you use. Other shapes will work, but the gain will suffer.

To support a square loop, you will need four supports, one for each corner. We hope you will have trees or masts in the right places. A triangular loop will need three supports. Once you have cut the single piece of wire to the right length, run the wire through as many insulators as you have corners. At each corner of the loop, put an insulator and tie the corner to a support with a rope from the insulator. To make the feed-point, connect both ends of the loop to an insulator. Strip the insulation from the outer part of the coax. Separate the shield from the

center conductor. The ends of the coax are connected to the ends of the loop across the insulator. Most hams do not feed loops with a balun at the feed-point.

## 14.2 The Vertically Oriented Single Loop for 40 and 80 Meters

Vertically oriented loops radiate broadside to the plane of the loop. A horizontally polarized vertically oriented loop has both vertical and horizontal wires. From here on out, we will refer to a vertically oriented loop as just a vertical loop. When using this term, we are not referring to its polarization. If the feed-point is on one of the horizontal wires, the loop radiates horizontally polarized waves. The vertical wires radiate weaker vertically polarized waves. If the feed-point is on one of the vertical wires, vertically polarized waves will be radiated. The radiation from a one-wavelength vertical loop has both high-angle and low-angle radiation. It is a good antenna for both nearby stations and for DX contacts. It is better than a dipole for DX because the vertical loop puts out a stronger low angle signal than a dipole does.

The gain of a vertical delta loop is 4.55 dBi or about 2.4 dBd. Its feed-point impedance is about 120.5 ohms. The square vertical loop has 5-dBi gain and about 2.85 dBd and the feed-point resistance is 143 ohms. They both need to be fed with a series quarter-wave matching section of 70-ohm coax.

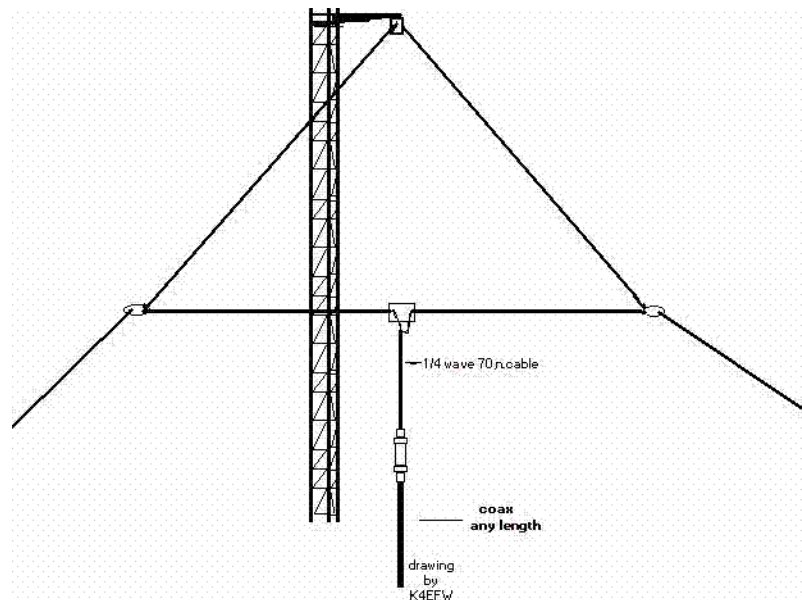
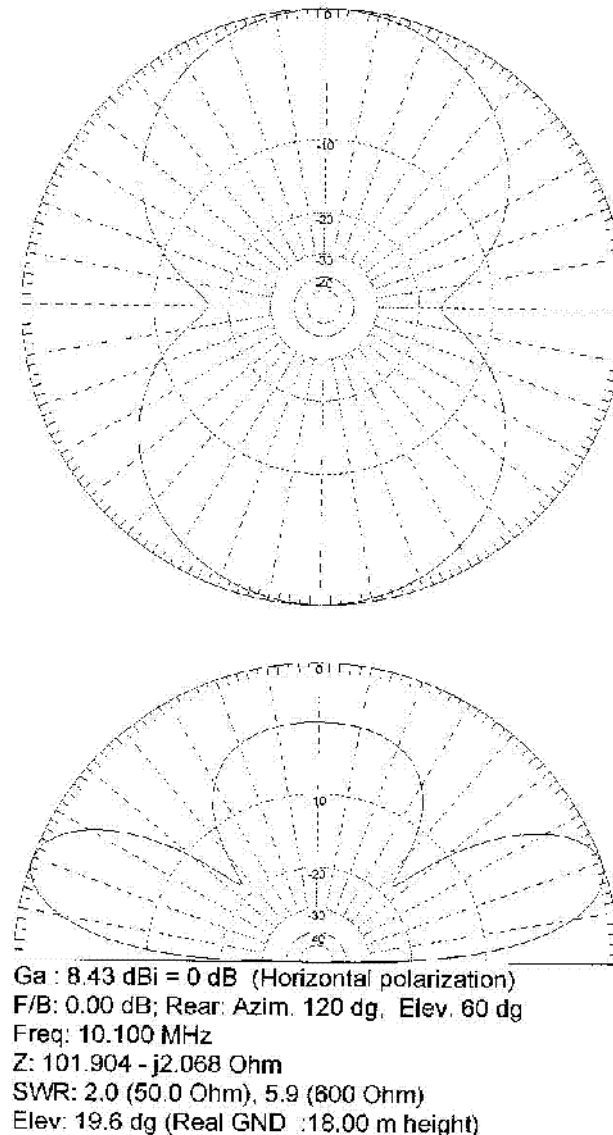

**Figure 14.2: One Wavelength Horizontal Loop Single-Element Vertical Delta Loop**

Square vertical loops need two supports. The square vertical loop needs less vertical space than the delta loop. The vertical space needed for a square vertical loop for 80 meters is 92 feet. For 40 meters the vertical space is half that. It is rare to find someone using the square vertical loop these days. The vertical delta loop is more common because it needs only one high support. The apex of a delta loop for 3500 kHz needs to be 102 feet high and on 40 meters, it needs to be 62 feet. This assumes the bottom horizontal wire will be 20 feet off the ground. In order to make a vertical loop fit on a shorter support, the sides of the loop can be

reduced in length while making the horizontal wires longer. This will put the two maximum current points closer together, which has the effect of reducing the gain.

Like the horizontal loop, the formulas for finding the length in feet of these loops are the same: 1005 divided by frequency in MHz. In addition, because the feed-point resistance is nearly the same as horizontal loops, quarter-wave matching sections and other methods can be used to feed the vertical loops. The vertical loop is not as sensitive to height as the horizontal loop. Both vertical square loops and vertical delta loops can be operated on harmonically related bands. (See *Figure 14.4: Radiation Pattern of a 30-meter Delta Loop on 15 Meters* on page 58).



**Figure 14.3: Radiation Pattern of a 30-Meter Delta Loop on 30 Meters**

The Bottom Wire is at 18 Meters above Ground.

The horizontal pattern shown above demonstrates that the 30-meter delta loop has a bi-lobal pattern broadside to the plane of the loop. The vertical pattern below the horizontal pattern shows both high angle and low angle radiation. The angle of maximum radiation is at 35 degrees above the horizon. The angle of radiation straight up is only down about 1.5 dB. This is pattern demonstrates the vertical delta loop is good for both nearby stations as well as DX.

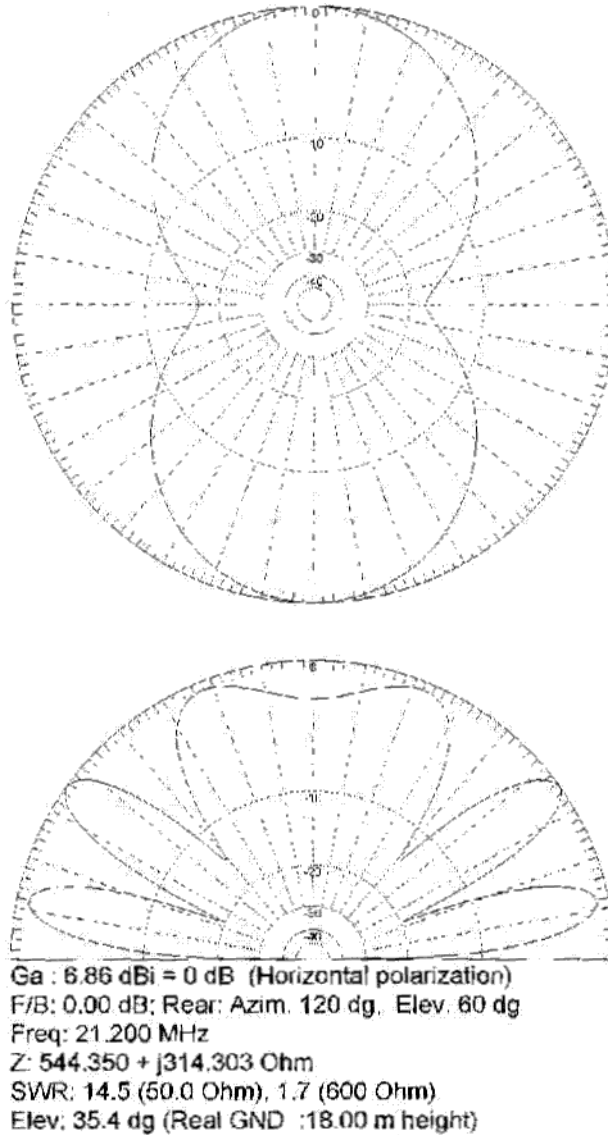

**Figure 14.4: Radiation Pattern of a 30-meter Delta Loop on 15 Meters**

# 15.

## *Directional Beam Antennas*

### 15.1 The Monoband Yagi

Between 1926 to 1929, Shintaro Uda and Hidetsugu Yagi developed a beam antenna that had sharp directivity and high gain. Later, work was done primarily by Mr. Yagi and yagi was the name given to the antenna until finally recognition was given to Mr. Uda. Its proper name is the Yagi-Uda Array. Most hams call it a beam.

A monoband yagi is the name given to a yagi for a single band. The performance of any commercially made monoband yagi is touted to have its dimensions tuned for maximum performance. As you will see later, this is not always the case. Monoband yagis being sold today are much improved over older designs because of computer modeling programs available.

The yagi is made of two or more aluminum elements mounted on and perpendicular to a boom. Hams use antenna rotors to turn the antenna in the direction of the station they want to work. However, there are wire beams, fixed in one direction, mainly on 80 meters, suspended between trees or other supports. Most high frequency beam antennas used by hams are in the horizontally polarized configuration, which means the elements are parallel to the ground. CB beam antennas and some 2-meter beams are vertically polarized with the elements at right angles to the ground (See *Section 3. Polarization Of Electromagnetic Waves* on page 5).

A 2-element yagi has a gain around 3 to 4 dBd. A two-element yagi will have a driven element with either a reflector or a director. The driven element is the only element receiving power directly from the transmitter. The reflector and directors are called parasitic elements because they receive power from the driven element by inductive coupling.

The 3-element yagi will have a gain of approximately 5 to 7 dBd or 7 to 9 dBi depending on its boom length. A three-element yagi has one reflector, one driven element, and one director. Because the yagi has a low radiation resistance, a matching system is located at the driven element feed-point. The ratio of the radiation off the front compared to the radiation off the back is called front-to-back ratio. Front-to-back ratio and forward gain are factors to be

considered in choosing a yagi design. Both measurements are given in dB. All yagis have a good front-to-side ratio, with the signal off the side being 50 dB below the front.

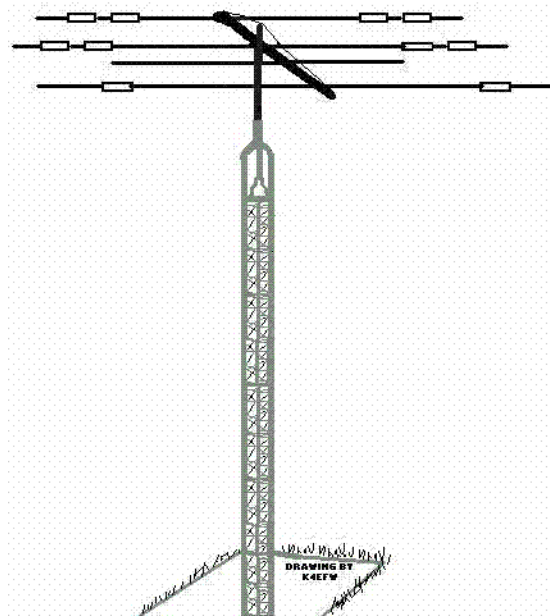
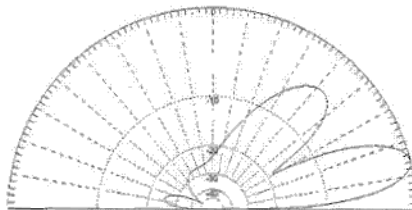
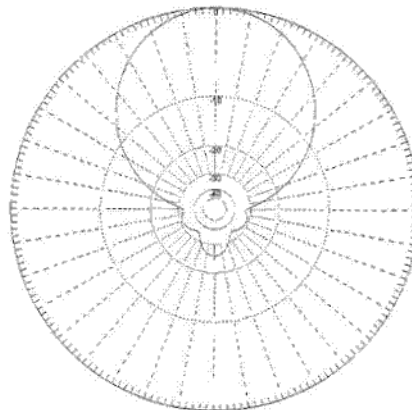

Figure 15.1: 3-Element Yagi



Ga : 13.47 dBi = 0 dB (Horizontal polarization)  
 F/B: 25.06 dB; Rear: Azim. 120 dg, Elev. 60 dg  
 Freq: 14.200 MHz  
 Z: 19.629 + j0.013 Ohm  
 SWR: 2.5 (50.0 Ohm), 30.6 (600 Ohm)  
 Elev: 14.4 dg (Real GND :20.00 m height)

Figure 15.2: 3-Element Yagi Radiation Pattern



The reflector of a yagi is about 5% longer than the driven element. The reflector, being longer, will have inductive reactance. The inductive reactance shifts the phase of the re-radiated wave, which radiates and combines with the driven elements wave and reinforces it in the direction away from the reflector toward the driven element. A director is about 5% shorter than the driven element. The director, being shorter, has capacitive reactance, and this changes the phase of the reradiated wave to reinforce the wave away from the driven element opposite the reflector.

The gain of a yagi is derived from radiation being concentrated in one direction at the expense of the other directions. One hundred watts fed into a yagi with a gain of 6 dBd will have an apparent power of 400 Watts in the main lobe. Because one hundred watts put into a yagi radiates only one hundred Watts, and because that one hundred Watts of power is concentrated in the main lobe, it is equal to the power from a dipole being fed with 400 Watts. This is referred to as effective radiated power or ERP, but a yagi is not any more efficient than other antennas. Because of the Principal of Reciprocity, an antenna having a 6 dBd gain on transmitting will also have a 6 dBd gain on receiving.

Adding more directors and increasing the boom length will increase the gain of a yagi.

The front-to-back ratio ranges from 18 dB for a 2-element yagi to over 25 dB for a multi-element yagi, provided the parasitic elements are carefully tuned. The gain of a yagi is generally proportional to the boom length and not necessarily the number of elements. Doubling the boom length, while keeping the proper number of elements for that boom length, will add about three more dB of gain.

Tuning the yagi for maximum gain makes the bandwidth very narrow, and it will have a poor front-to-back ratio. For these reasons, we don't recommend tuning a yagi for maximum gain, because you will only increase the gain by a fraction of a dB at the expense of front-to-back and feed-point impedance. Tuning the yagi for maximum front-to-back will help eliminate interference coming from the rear of the antenna. The building of any yagi involves compromise spacing and element tuning.

As you make the yagi larger by adding directors, the main radiation lobe becomes narrower increasing the gain and ERP. The gain of a yagi with four elements is about 7 to 8 dBd. You used to see 3 or 4 element yagis advertised claiming a gain of more than 10 dB, but they never said if that gain was referenced to an isotropic or a dipole. That gain also involves the gain derived from signals reflected from the ground adding to the direct wave. A more realistic gain figure is the "free space gain." Some companies, who sell monoband yagis, inflate their gain figures. Beware! Increased spacing of the elements will increase the gain of a yagi up to a point. Increasing the spacing past that point will reduce the gain. The spacing of a reflector or director needs to be in a range of 0.1 to 0.3 wavelengths. With a 3-element yagi maximum gain occurs with both parasitic elements spaced at about a quarter wavelength. Second and third directors can have wider spacing.

Most hams do not build yagis but buy them from the many companies who sell them. Ham catalogs are full of pre-cut and tuned yagis that come in boxes ready to be assembled in the back yard. Many of these are very good. However, there is a lot of satisfaction to be gained from building your own.

In 1971, we purchased, a 15-meter monobander being sold by a reputable company. Its performance was disappointing. It had only a 10-dB front-to-back ratio. That design is no longer being sold. After reading some books, we readjusted the antenna elements to some new dimensions and it performed much better. This was the beginning of our yagi building.

During the last nearly 50 years, we built many yagis. During the period of 1979 until 1986, many multi-element yagis were constructed, gain measured, formulas derived for spacing and element length, and the radiation patterns plotted on graphs. In 1986, a computer program titled *Yagi* by Dean Straw, N6BV, was bought. From that point on, that program was used to design and set the element lengths to their proper values. Not much difference in performance of the new designs was seen over what was previously used, but tuning parasitic elements and running back and forth to the field strength meter was eliminated. There are many better computer programs available today for designing yagis and other antennas.

The largest yagis we built were a 4 element 20-meter yagi on a 38-foot boom, a 5 element 15 meter one on a 27-foot boom, and a 5 element 10 meter beam on a 24-foot boom. These are modest designs compared to some of the big antennas used by contest stations. All these yagis were stacked one above the other on a 20-foot mast coming out of the top of the tower. The 20 meter one was on the bottom, next came the 15-meter, and the 10-meter yagi was on top. This method of stacking yagis for different bands one above the other makes what is called a “Christmas tree array.” These antennas worked well. Since retiring and moving back home, we use pre-tuned directional antennas because of the lack of a good place for an antenna range. Climbing is not now an option because of age and infirmity.

If you make the reflector 5% longer than the driven element and the director 5% shorter than the driven element, you will be pretty much in the ballpark. The beautiful part about a yagi is it will work reasonably well with the element lengths only in the ballpark. By carefully tuning, you will get a fraction of a dB more gain or a few more dB front-to-back, because the spacing and diameter of parasitic elements affect the length required for those elements. A yagi can be tuned for maximum forward gain, maximum front-to-back ratio, or best impedance, but you can achieve only one of these conditions at a time. Element tuning, at best, is a compromise.

Most hams who are yagi builders do not tune their antennas at all, but use published dimensions for building them. Yagi builders who do tune, tune for either gain or front-to-back and then match the driven element with a gamma match, hairpin match, a series-resonant coax matching section, or a step down balun. The feed-point of a properly tuned yagi is close to 25 ohms.

Formulas for calculating yagi element lengths will not be given in this book. Because yagi elements are made from telescoping aluminum tubing, the elements will be tapered. The diameter of the elements and the taper determine the lengths required for tuning of the elements. A tapered element will resonate higher in frequency than one not tapered. The formula to calculate the length of the tapered elements is complicated, but there are computer programs to do that.

## 15.2 Trapped Multi-Band Yagis

Some yagis have traps in the elements to make them into a multi-band beam. Many of these commercially made antennas are available at ham radio stores or directly from the

manufacturers. In a 3-element, 3-band design, the spacing on the booms is a compromise. A 3-band beam is known as a “tribander.” The spacing is close on 20 meters, optimum on 15 meters, and wide on 10 meters. You cannot tune the trapped elements for maximum performance on three bands simultaneously and have a good match on all those bands. Since a good match is important to most hams, gain and front-to-back ratio are sacrificed for a good match on triband beams

The inductors in the traps load the elements in triband beams. Therefore, the elements are shorter than the elements of a 20-meter monobander. Regardless of the compromised design, a triband-trapped beam is much better for working DX than a dipole. Many hams have achieved working over 300 entities with tribanders having short booms.

The radiation pattern from a yagi is at a lower angle than a dipole. This gives the impression a yagi has much more gain than it does. A dipole has unity gain, but that gain will be at a higher angle. The dipole puts out a weaker signal at the low angles needed to work DX, and a yagi puts a strong signal at low angles. In comparing a dipole to a yagi, the yagi may only have a 4 dBd gain in its major lobe. The gain of the yagi at a low angle may be 10 dB or so better than a dipole at that same lower angle. The gain of any antenna is always measured in its major lobe, irrespective of where the angle at which the maximum radiation lobe occurs.

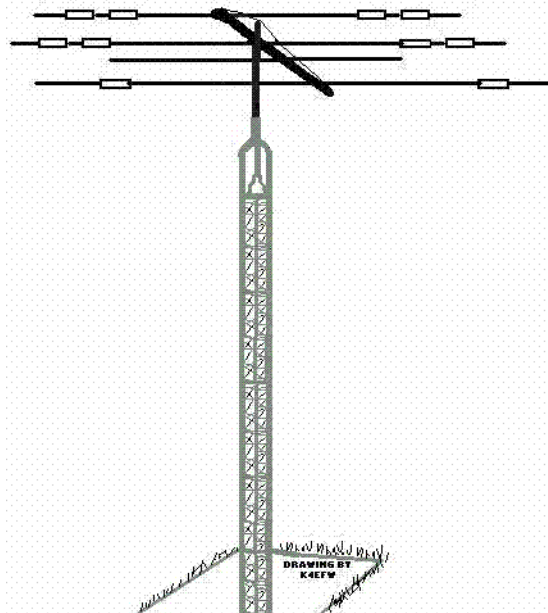

**Figure 15.3: Trapped 3-Element Yagi**

*Figure 15.3: Trapped 3-Element Yagi* shows two sets of traps in two of the elements and one set in the rear element. The front element is the director with traps for 10, 15, and 20 meters (it takes two sets of traps to make the elements work three bands). Directly behind it is the driven element with traps also for 10, 15, and 20 meters. The rear element is trapped for 15 and 20 meters (a single set of traps makes it work two bands). The entire lengths of the three longest elements are resonant on 20 meters. The short element is a reflector for 10 meters. Only the part of the antenna between the 10-meter reflector and the front director is used on 10 meters. The maximum signal is radiated in a direction coming out of the page toward you. Mosely

builds trapped antennas that have two traps in one enclosure and you can not determine the bands from the traps as you can on Hy-Gain and Cushcraft beams.

Some triband beam models as the one above are built with longer booms so they would have more gain on 20 meters, a good match on all bands, and optimum 3-band performance. They achieve this by interlacing extra monoband reflectors and directors on the boom placed between the 20-meter elements as is done with the antenna in *Figure 15.3: Trapped 3-Element Yagi* on page 63. The extra elements have no effect on 20 meters or any band for which they are not resonant. Some amateurs mistakenly think the extra elements work on all bands, but they don't. The Cushcraft A-4 shown is not a beam with four working elements on any band. The old Hy-Gain TH6DXX and Mosley Classic 36 had six elements on the boom. They both had three trapped elements and three monoband elements. They had three working elements on 20 meters, three on 15 meters, and four elements on 10 meters. The trapped reflector worked on 15 and 20-meters. The trapped driven element worked on all three bands. The trapped director worked on 10 and 20 meters. On the boom was a resonant reflector for 10 meters and one each resonant directors for 10 and 15-meters. When using one of them, we have often heard amateurs saying they were using a six-element beam. This gave the other station the mistaken idea they were working someone with an antenna with six working elements. Other beam antennas interlace additional elements of different lengths to make the tribander into a 5-bander covering 20, 17, 15, 12, and 10 meters. Hy-Gain makes a 5-band yagi for 20 through 10 meters that has 11 trapped and monoband elements. It is the Hy-Gain TH-11. Mosley makes a 6-bander that includes two elements for 40 meters. It is the Pro-67.

In order to achieve better SWR curves over a wide bandwidth, some triband yagis have two driven elements spaced 3 to 5 feet apart. The front driven element is shorter than the rear driven element. Both driven elements are trapped. This double driven element scheme is called a log-cell. A log cell, by itself, has a small gain and may slightly increase the overall gain of the tribander. The KLM KT-34 and the HY-Gain TH-7 are examples of this kind of antenna.

Is a monobander better than a tribander? We don't know if our tests can be duplicated and no one else has ever said he has actually compared the two antennas. It is "common knowledge" that traps have loss. Therefore, the ham fraternity believes a monobander has to be better. From the tests we performed here, we believe it is a myth a monobander is significantly better than a tribander having an equal boom-length. We believe the traps do not have enough loss to make enough difference to matter. However, monobanders having very long booms and many directors will outperform any tribander.

Having two towers, both having the same height and being 100 feet apart, made it possible for us to do the experiment described here. The result is useful information because it was made in a real world situation that would be comparable to the average hams location. Both antenna element lengths were set to Hy-Gain specifications. The constants were terrain, antenna height, antenna boom length, frequency, coax length, and power level. The only variable in the tests was the two antennas being tested. The test was performed to see how much loss antenna traps have. Had there been more than one variable, the tests would not have been valid, because in any scientific experiment, the test is valid only when one variable is being tested. In addition, more than one test has to be made in order to average out the collected data errors. In this case, many tests were made.

On one tower was a 20-meter four-element Hy-Gain 204-BA monobander with a boom-length of 26 feet. This antenna is arguably not one of the best monobanders made, but it is what we had and it was about the same size as our tribander. On the other tower was a trapped 6-element Hy-Gain TH-6 DXX tribander having a 24-foot boom. The entire tribander boom-length was used on 20 meters, so both boom-lengths were comparable.

The transmitted signal strength of the two antennas was compared on 20-meters. This test involved many DX stations and one local amateur 5 miles away. With both antennas pointing toward the receiving station, a carrier power of 10 watts was fed from the transmitter, and held constant while the antennas were “hot” switched several times. (The power level was unimportant as long as it was held constant on both antennas). None of the many DX stations involved in this test could see any difference in either antenna, and, yes, their analog meters could discern a difference of one dB. These tests by themselves were not conclusive because of the possibility of fading signals (QSB). A second series of tests was performed with a local ham when 20 meters was dead. Testing with him was done to eliminate QSB from spoiling the results. He could also measure no difference on his S-meter. He could also see a one-dB difference on his analog S-meter. As a third series of tests, the antennas were switched while we looked at the signals on the S-meter from distant stations and the local station. No differences in received signals were noted. Maybe the difference was a monobander has only a few tenths of a dB less loss, such a small amount of difference no one was able to see it on receiver S-meters. Certainly, the difference in the two antennas was less than one dB.

Conclusion: The Hy Gain TH6DXX and the 204-BA antennas perform equally well on 20 meters at a height of 56 feet.

## 15.3 The SteppIR Antenna

The latest developments in yagi designs are found in the ones being sold by SteppIR Antennas. There are two, three, and four element versions. All these versions are frequency agile and cover continuously from 13.5 to 54 MHz. The MonstIR adds three very long elements for 6.9 to 13.5 MHz. The elements are made of fiberglass tubes with beryllium-copper ribbons inside. Each element has stepping motors to wind and unwind the copper ribbons to change their lengths inside the tubes. A multi-wire control cable connecting the control box to the stepping motors accomplishes this. The proper element lengths for all frequencies in its range have been calculated by a computer and stored in the control boxes computer. As you move from frequency to frequency, the control box in the shack readjusts each element length. Thus, the antenna is configured into a properly tuned monobander for any frequency in its range. These antennas are expensive, but the hams who own them say they are worth the money.

## 15.4 The Log-Periodic Array

Another beam antenna that looks like a yagi is the log-periodic antenna. It is configured using many elements with each element being shorter than the one behind it. This means the longest element is at the rear of the array and the shortest element is at the front. All elements are divided in the center and insulated from the boom, and all elements are driven. On both sides of the insulator at the center of each element, wires run from the front element of the array to the rear element. Each wire criss-crosses the other ones but they do not touch. That makes a 180-degree phase reversal from one element to the next one behind it. The feed-point is across

the insulator at the shortest element. The feed-point impedance is about 200 ohms and a 4:1 balun is used to feed it.

The advantage of the log-periodic antenna is, it that it is very broad banded and it can cover all frequencies with an SWR below 2:1 in its design frequency range. The disadvantage is the gain of a log-periodic antenna is lower than a yagi with an equal boom length. There are designs being sold today that cover continuously from 14 to 30 MHz. In Fort Gordon, Georgia, there used to be a monster log-periodic at the MARS station that covered from 2 to 30 MHz. The boom length was 120 feet and the antenna was rotatable.

## 15.5 Directional Cubical Quad and Delta Loop Antennas

We built a number of quads at various times and with them on the test stand and with the bottom wire a foot or so above the ground, worked many DX stations. When we built yagis and they were on the same test stand nine feet above the ground, we could hardly get a signal out of the back yard. Since the vertical beam-width of a quad is narrower than a yagi and the radiation angle is lower, the quad will work better at low heights. Because of its lower angle radiation, many quad users claim a quad “opens and closes” the band.

The two-element cubical quad is a square-or diamond-shaped loop antenna that has a second loop acting as a parasitic element. The quad configuration has all loops in the vertically oriented plane as *Figure 15.3: Trapped 3-Element Yagi* on page 63 demonstrates. Feeding it in one of the horizontal wires results in horizontal polarization, and feeding it in one of the vertical wires makes it vertically polarized. Every two-element quad being sold today uses a reflector for the parasitic element, although it is possible for it to have a director. The theory of operation is the same as that of a yagi.

Some quad builders believe a diamond-shaped quad has more gain than a square-shaped one. Their logic is that since the maximum current points of both wires are spaced farther apart than with a square quad, the increased spacing of the current points should produce higher gain. To find out if this was true, we built both a diamond-shaped and a square-shaped quad for two meters. Using a commercial field-strength meter connected to a receiving antenna, we fed equal amounts of power to both antennas and measured the radiated field in each ones major lobe. Field strength measurements were made a few wavelengths away and many wavelengths away from the quads. No difference in the radiated field of either could be found.

According to Bill Orr in his book about cubical quads, a two-element cubical quad is equal to a pair of 2-element beams; one is stacked over the other a quarter-wavelength. The ends of the beams bottom driven element are bent up and the top element has its ends bent down where the ends of the top and bottom elements are joined together on the side. When they are joined, this forms the square we call a quad. The bottom element is then feeding the top element from its ends. The parasitic elements have the same configuration except the wire loop has the ends bonded together to form a continuous square.

There are multi-element quad designs that use one or more parasitic directors in addition to the reflector. Adding a director will lower the feed point impedance. The wire of the reflector is about 3% longer than the driven element, and each director has about 3% less wire than the driven element. Adding directors to a two-element quad makes the horizontal beam width narrower, producing more gain.

Another quad design “the delta loop” uses triangular-shaped driven elements. One or more triangular-shaped parasitic elements make the antenna complete. Theoretically, the delta loop antenna will have slightly less gain than the cubical quad, because there is less enclosed area in the triangular loop. We believe that there are no instruments available to hams to be able to measure the difference.

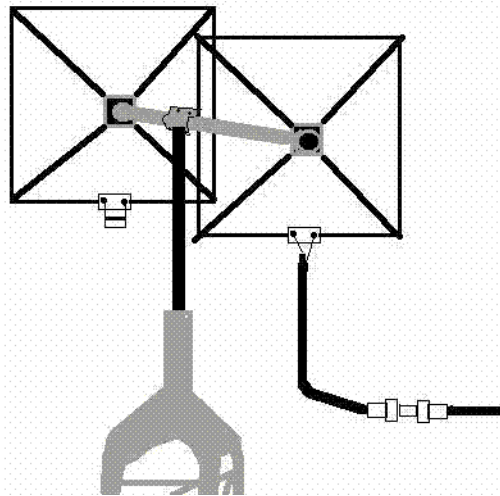

**Figure 15.4: Single Band Cubical Quad**

Most cubical quad and delta loop antennas that can be rotated are used on 20 meters and higher. A few ambitious hams have built rotatable quads for 40 meters. Others have made 80-meter quads, supported between trees, fixed in one direction.

In order to make the quad smaller, adding loading coils or linear loading sections in its wires has been suggested, but that will defeat the purpose of using a quad. Because the quads gain is produced by the enclosed area inside the loop, reducing the enclosed area will result in less gain.

The wires for quads for 20 through 10 meters are strung around the perimeter of an “X shaped frame made of fiberglass poles or bamboo. Each element has its own X-shaped frame. A smaller X-shaped metal structure, called a “spider,” attaches the poles to the boom. The poles are referred to as “spreaders.” The four spreaders attached to the spider form the “X.” The “X” can be rotated 45 degrees on the boom to form a diamond-shaped quad instead of a square quad. A few have tried with limited success to make the spreaders out of PVC or aluminum.

A wire is attached near the ends of the spreaders to form a loop around them. The two ends of the wire are connected to an insulator to attach the feed-line as is done on a dipole. The quad loop has a theoretical feed-point impedance of 100 ohms. To match it, you can use a quarter-wave matching section of 70-ohm coax, a gamma-match, or a 2:1 balun. More on this is in another paragraph. The delta loop is made much the same way, but it requires only three spreaders to form an equilateral triangular loop. It is matched the same way since the feed-point impedance is about the same.

The reflector and director are formed the same way as the driven element except the two ends are shorted together to form a continuous loop. In order to get maximum performance from a

quad you need to tune the reflector for either maximum gain or best front-to-back ratio. For tuning purposes, the wire of the reflector is cut a little shorter than calculated and the ends of the loop are connected to an insulator. A shorted stub, consisting of two parallel wires, is connected to the loop ends and hangs down from the insulator. Another wire is shorted across the two parallel stub wires. The shorting wire is moved up and down the stub to tune the reflector. The stub is a means of adjusting the total length of the reflector. See *Figure 15.4: Single Band Cubical Quad* on page 67. A field strength meter is needed to do this and you need a large area and two people. The field strength meter needs to be placed several wavelengths away from the antenna. Low power is fed into the antenna while it is tuned. One person tunes the reflector while the other person reads the field strength meter. Tuning the reflector involves tuning the stub for minimum signal off the back. Once the shorting wire has found its proper position, it is soldered in place. Quads made by the formulas work satisfactorily without tuning. Tuning for maximum front-to-back ratio instead of maximum gain will do more for the performance of the quad.

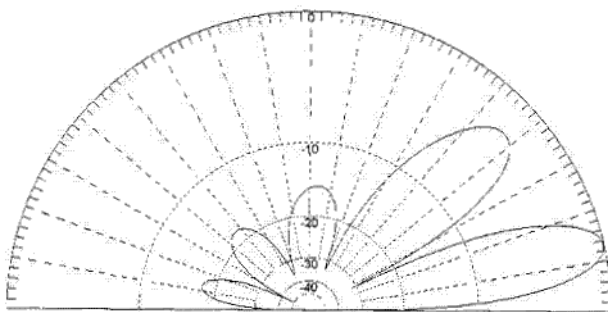
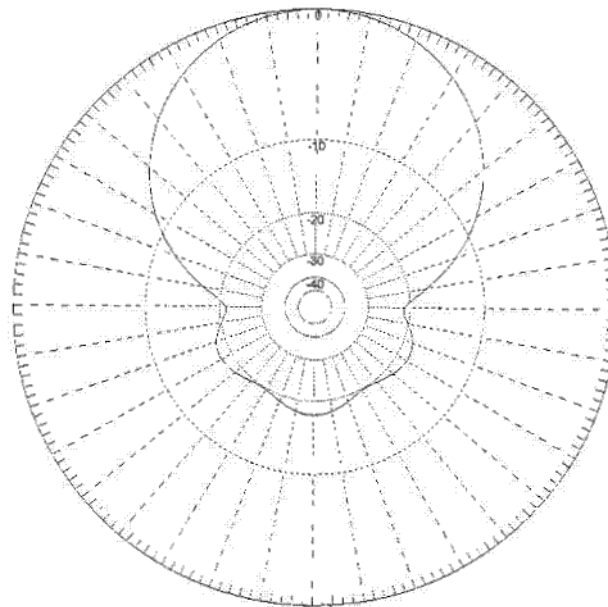

Ga : 13.36 dBi = 0 dB (Horizontal polarization)  
 F/B: 17.62 dB; Rear: Azim. 120 dg, Elev. 60 dg  
 Freq: 14.150 MHz  
 Z: 86.586 - j2.470 Ohm  
 SWR: 1.7 (50.0 Ohm), 6.9 (600 Ohm)  
 Elev: 13.1 dg (Perfect GND :20.00 m height)

**Figure 15.5: Radiation Pattern of a Two Element Cubical Quad at 65 Feet**



Some believe you cannot stack another antenna above a quad. They assume that because the quad has both vertical parts of the loop, a metal vertical mast will couple to the vertical part and detune the quad. We believe a vertical mast will have to be resonant at the operating frequency to detune a quad. Using MMANA, the quad was modeled with a metal vertical mast going through the plane of the quad. The only difference observed was that the resonant frequency was changed by a couple of kHz. The gain and front-to-back remained the same.

The gain of a two-element quad is nearly the same as an average 3-element yagi. The best part of the gain of a quad is the vertical beam width, or H-plane of the major lobe logically should be narrower due to it being equal to two stacked beams. For this reason, the 2-element quad has a lower angle of radiation. A horizontally polarized quad should have a slight advantage over a yagi. A lower angle is better for working DX. While operating using both quads and yagis, we have noticed that the horizontal beam width or E-plane of a quads pattern is wider than a 3-element yagi. We believe the horizontal beam-width of the quad is the same as a two-element yagi. This is why the 2-element quad is not as directional as a 3-element yagi.

Modeling our 2-element quad in free space on 20 meters, we found its gain to be 5.49 dBd. The boom-length of the quad is 8 feet. A three-element yagi with a boom-length of 16 feet will have 6.4-dBd free-space gain on 20 meters. The free-space gain of a 20-meter optimum spaced monoband yagi on a 25-foot boom will only have slightly more gain.

The compromise spacing for a 2-element multi-band quad for 20 through 10 meters is 8 feet. This spacing is 0.115 wavelength on 20 meters, 0.175 wavelengths on 15 meters, and 0.23 wavelengths on 10 meters. These spacings are within acceptable limits. For a single-band 20-meter quad, space the elements 12 feet apart. If you want to build a 12 and 17-meter dual band quad, the spacing will be 8 feet, the same as it should be for 15 meters. Eight feet is also a satisfactory spacing for a 10-meter quad, but it can be as close as four feet.

With smaller perimeter requirements, loops for the higher bands can be strung inside and parallel to the lower band loops to make a multi-band quad. It is easier to make a multi-band quad than a multi-band yagi. Quad kits for triband and 5-band quads are available. These kits cost less than a multi-band beam.

In the construction of most quads, an insulator is put in the bottom horizontal part of the wire on the driven element so it can be fed like a dipole. A 2-to-1-balun transformer will match the feed-point to 50-ohms, then you can tie all the feed-points of a multi-band quad together. The Lightning Bolt Antennas 32MCQ/WB quad feeds five loops this way and the SWR is 1.4:1 or less on all five bands. The person manufacturing the Lightning Bolt quad went out of business on December 12, 2005.

With other more complicated schemes, each quad loop is fed separately, and each loop uses a 70-ohm odd multiple of a quarter-wave series matching section placed between the 50-ohm coax and the feed-point. Used this way, the quarter-wave matching section will match 50 ohms to 100 ohms. A remote antenna switch will have to be mounted close to the feed-point to select the desired loop. Other builders use a separate gamma-match on each driven element to get a perfect match to a 50-ohm coax but this method would also require a remote antenna switch. Without the switch, several pieces of coax, one for each band, would have to be run into the shack.

If you are going to build a monoband quad, you need to use the following formulas to cut the wire loops to these approximate lengths:

- For the driven element, you divide 1005 by the frequency in MHz.
- For the reflector, you divide 1030 by the frequency in MHz.
- For the director, you divide 968 by the frequency in MHz.
- Make any additional directors the same length as the first one

These formulas were derived experimentally from tests run here. The exact measurements will be determined by the element spacing, but the lengths cut by these formulas will be very close for any reasonable spacing.

After giving you the advantages of a quad, here are the disadvantages: The two-element quad for 20 meters is large vertically and horizontally. When the 20-meter quad is on the ground, the boom is 8 feet high and most people aren't tall enough to maneuver it by holding the boom. Some quads, which are made from lightweight materials, are flimsy, and they will suffer during wind and ice storms. The best-constructed quads have their spreaders made of heavy fiberglass. Those quads, although they are heavier, stand up well under adverse weather conditions. The Lightning Bolt quad used here has stood up very well during three ice storms in the past two winters.

Here is some information we discovered after originally writing this book. The MMANA antenna-modeling program does not perform very well when modeling a quad. On 20 meters, the modeling program says the front-to-back ratio of our quad is at a maximum at 14525 kHz, but actually, it occurs at 14050 kHz. The measurements of actual front-to-back were made using a field strength meter. We reduced the power levels off the front to give the same field strength reading we got off the back. The front-to-back ratio in dB was calculated from the two power levels. What was interesting was the maximum front-to-back ratio occurs at a single discrete frequency and the front-to-back deteriorates somewhat on either side of that frequency. While looking at the radiated field off the front, the field strength does not vary one dB across the whole band. Maximum gain and maximum front-to-back was very close to the same frequency. Not having tested them in this way, we believe yagi beams perform the same way regarding front-to-back ratio and gain. In working stations, the gain is the important parameter. Front-to-back ratio is important in reducing interfering signals from behind the antenna. We decided to tune our quad for maximum front-to-back rather than for maximum gain. The next step is to lower the quad and carefully tune the reflector for each band. After running tests to determine the frequency where maximum front-to-back occurs, we found the maximum measured front-to-back ratio was 22 to 23 dB.

Good news! After writing the above paragraph, we lowered the multi-band quad and reduced the reflector element lengths on the two-element Lightning-Bolt Quad. The original reflector lengths were too long according to the field strength readings we made. The formulas that were originally used to cut the reflector lengths were anywhere from 1029 to 1036 divided by the frequency in MHz. We derived from field-strength measurements that the maximum front-to-back ratio occurred when the reflector length was cut by dividing 1022 by the frequency in MHz. While searching the Internet, we discovered EI7BA in Ireland used 1019 divided by the frequency on his multi-band quad. We decided to use his formula and we could lengthen the reflector by adjusting the stubs if necessary. After cutting the reflectors to the new dimensions, we made new field strength readings. The front-to-back ratio occurred near the

frequency of our calculations. In addition, the frequency of maximum field strength from the front also occurred inside each band. As an example, today we were listening to GD4PTV on the Isle of Man on 17 meters. On the front of the quad, he was S7. With the quad 180 degrees from him, he was inaudible. We also found that other stations were down by at least six S-units off the back. Originally, stations off the back of the quad were down only two S-units.

Several months later it was discovered that a multi-band quad tunes differently from a single-band quad because the interlaced elements react to detune each other. That may be the reason we found the reflectors of a multi-band quad needed to be different lengths than the  $1030/\text{frequency}$  formula.

Here are some words of wisdom about using a field-strength meter in trying to tune a quad:

Tuning the quad reflector stubs can give you misleading data. If you look only for the minimum signal from the back of the quad, that may not be the point of best front-to-back because you may have detuned the quad so that the signal from the front may have also deteriorated.

Using a field strength meter, keep the receiving antenna as short as possible to prevent the receiving antenna from being nearly resonant. Certain receiving antenna lengths seem to be frequency sensitive, that is, as you change frequency toward the receiving antennas resonant point, the field strength meter will give a false higher reading. The only problem with using a very short receiving antenna is the meter may not have enough sensitivity to make measurements from the back of the antenna.

It will be impossible to achieve a high front-to-back ratio on certain bands on a multiband-quad because the reflector wires for adjacent bands affect the tuning by interacting with each other. When the Lightning Bolt Quad was designed, we are not certain which parameter was used in its design (gain, SWR, or front-to-back). From the field strength readings made with that design, it was impossible to draw any conclusions. If you are going to build a quad, what we said about designing a yagi is also true for the quad: you can tune for best gain, best front-to-back, or best impedance match. You cannot tune for more than one of these parameters at a time. To tune a quad for maximum gain is relatively easy using a short antenna on the field-strength meter.

While we were trying to measure the frequency of the highest forward gain on 17 meters, we found the maximum field strength occurred at the high end of the band on one receiving antenna. Subsequently, it was strongest on the low end of the band on another receiving antenna having a different length. No changes had been made to the dimensions of the quad in either case. Trying to move the frequency of the maximum field to the middle of the band, we adjusted the length of the reflector stubs and it made no difference to the frequency where the maximum field occurred. What caused the error was we were trying to measure the field strength 100 feet in front of the quad. The long receiving antenna connected to the field strength meter was acting like a parasitic element and was not accurately measuring the signal being radiated from the quad.

## 15.6 The Quagi

A variation of the quad and the yagi is a marriage of the quad and the yagi called the quagi. The quagi has a quad driven element, quad reflector, and yagi directors. Hams who have built the quagi report the yagi directors work better than quad directors, but we have never compared the two types of directors.

At one time we converted a 2-meter yagi to a quagi and compared the field strength readings from both configurations. By changing the driven element and reflector to quad loops, we measured a signal increase of 1.8 dB. We also experimented to see what effect the quad reflector had on the signal. While using the quad driven element we changed the reflector back to a yagi reflector. What was surprising to us was the configuration of the reflector had no affect on the radiated signal. Only by changing the driven element from a yagi element to a quad element made any change in the field strength. All these field strength readings were made using a commercially manufactured field strength meter. To insure our readings were valid, the power being fed to the antenna was measured and kept constant.

# 16.

## ***Gain Versus Front-to-Back***

As we have said before the front-to-back ratio of a multi-band cubical quad can be maximized by careful tuning to achieve about 18 to 20 decibels front-to-back ratio. A properly designed yagi can achieve a front-to back ratio of better than thirty decibels. A two-element quad has about the same gain as a three-element yagi. You can tune a yagi or quad to either maximum front-to-back or maximum gain. You can also tune them to compromise settings somewhere in between. The question arises as to which maximum should either antenna be tuned? It is our opinion that either antenna should be tuned for maximum front-to-back ratio. In that case the maximum gain will be deteriorated by only a fraction of a decibel. Let us explain why we reached that conclusion with an example.

Today we were on 17 meters to work VP8TD on Pitcairn Island in the South Pacific Ocean. He is a visitor to the island and will be there for about two more months as of this writing. A resident of the island, VP6TC, Tom Christian hasnt been heard from in months. I suspect he is getting elderly and doesnt get on much anymore. Anyway VP6TD had an enormous pileup going. We were using a three-element SteppIR yagi up sixty-five feet on our tower. Also, the amplifier puts out about 1490 watts on 17 meters. We make up for a lack of antenna forward gain with the amplifier. We worked him with one call through the pileup. The SteppIR replaced the two-element Lightning Bolt Quad about 10 months ago. When VP6TD answered us I could hear him over the pileup. From the rear of the antenna were several very loud Italian hams calling him, one of which continued to call even when VP6TD answered someone. The Italians were 180 degrees from the front of our antenna, or directly off the back of where we were beaming. Because of the superior front-to-back of the yagi, I could hear the Pitcairn Island station over the Italians. Had we been using the quad, the Italians would have been at least 10 dB louder and we could have found it impossible to make the contact.

Today, we were in contact with N4XPZ, Joe, on 75 meters while several more hams were talking about the VP6TD on 17 meters last evening. Joe said he tried to work the VP6TD station using a single wire antenna. He complained he could not copy the VP6 because of the Italians who continued to call even when the VP6 answered someone. That illustrated the point we are making in this section. The old adage is true: “You can’t work ‘em if you can’t hear ‘em!”

# 17.

## ***Feed-Lines Commonly Called Transmission Lines***

Always use the best feed-line you can afford. Resist the urge to be penny wise and pound-foolish. This is particularly true of coax. Better (less lossy) coax will cost more. This cable is carrying your precious RF signal to and from your antenna.

The most common feed lines used by amateurs are 50-ohm coaxial cables. There are many types of 50-ohm coax such as RG-174, RG-58, RG8-X, RG-8, RG-213, RG-8 foam, and 9913. In this book we will only discuss these types. A suffix letter such as an “A” or “U” may be attached to the “RG” numbers such as RG-8U or RG-58A. All these cables have a center conductor surrounded by a plastic insulating material, called the dielectric, and a copper braided shield covering it. There is a plastic covering on the outside of the shield to protect the conductors from water. The center conductor and the shield carry RF currents.

These are the common 50-ohm cables:

- RG-174 has a very small diameter, 0.101 inches. This cable is used to carry small amounts of RF between circuits in equipment. RG-174 has the highest loss and the least power handling capability of any coax. It is useless as an antenna feed-line because of its loss and low power handling ability.
- RG-58 is larger coax having a diameter of 0.195 inches. It can handle low power and can be used on the lower bands to feed antennas a one hundred feet or so away. It is not recommended to use RG-58 on 10 meters because it has a loss of 3dB per hundred feet on that band and half your power will be lost in the coax.
- The next larger cable is RG-8X, sometimes referred to as mini-8. Its diameter is 0.242 inches. The dielectric surrounding the center conductor is foam rather than the solid dielectric used in the most coax. Making cables with foam insulation can reduce the loss. Some hams are successfully feeding a kilowatt of power into RG8-X on the lower bands. You will lose 2 dB of power by using one hundred feet of RG-8X on 10 meters. On 80-meters the loss of this cable is negligible.

You will want to use RG-8 or RG-213 if you are planning to use a kilowatt or more of power from 160 to 10 meters or for short runs on VHF and UHF. RG-213 is RG-8 made to military

standards. Both have diameters of 0.405 inches. This cable has lower loss and can handle higher power because it has larger conductors and a larger diameter dielectric. RG-8 can handle 4000 watts peak envelope power on the broadcast band. RG-8 has only about 1dB loss on 10 meters per 100 feet. The loss becomes greater and the power handling rating of any coax decreases as the frequency of RF is increased.

There is a lower-loss version of RG-8. It is called RG-8 foam. Beldens number for this product is 8214. Because of the dielectric being foam, a larger center conductor has to be used to keep the impedance 50 ohms. The loss resistance of the larger conductor is less than the smaller conductor used in regular RG-8. In addition, the foam having many air pockets has less dielectric losses. Other manufacturers also make RG-8 foam. One hundred feet of RG-8 foam has a loss of 0.9 dB on 10 meters. Many amateurs will not use RG-8 foam because they mistakenly believe the foam will soak up water. Cut off a piece of this foam material and put it into a container of water. It will continue to float ad infinitum, because it doesn't soak up water. Most of the water seen in coax gets between the dielectric and the plastic outer covering and within the braid shield. Water has also gotten into the strands of the center conductor. Water will get into any coax if the ends are not properly sealed.

Solid conductors have less loss at radio frequencies compared to stranded conductors. Braid has more loss than a solid conductor used for the coax shield. A much lower loss coax, especially for higher frequencies, is available. The Belden 9913 is this product. This coax has a solid center conductor and the shield consists of a coating of aluminum foil covered with braid. The aluminum foil is a solid conductor. The braid over the foil is used to make a good solder connection because you can't solder aluminum. The mostly air dielectric material used in this product requires the center conductor to be larger to make the impedance 50 ohms. Air dielectric also has less dielectric loss than solid. There are a few manufacturers making 9913 look-alike products. One hundred feet of 9913 will have a loss of about 0.66 dB on 10 meters. There is a coax that looks like 9913 but has a stranded center conductor to make it flexible. It has a little more loss. If you are going to use 9913 on an antenna that rotates, flexing the cable as the antenna turns will cause the center conductor to break. Run the 9913 to the top of the mast, and using a barrel connector, connect the 9913 to a short run of RG-8. Run the RG-8 across the rotor to the antenna.

Coax cables of other impedances are available such as 70-ohm cable. RG-59 and RG-11 are common 70 ohm cable. Hams, except to make quarter wave matching sections, do not use these cables much anymore. There are many other types of cable other than the ones described here.

Open wire feeders, ladder-line, or window-line have much lower loss than coax. The three types are essentially the same except for the method of insulating the two wires from each other. When making open wire feed-line, you should use solid conductors, as large a conductor as possible, and as little dielectric as possible. These factors make open wire have less loss. There is so-called ladder-line for sale, which is really window line, which is made with 16 gauge solid conductors. The solid conductors make for low loss. There is another grade of the same feed-line that has 14 gauge-stranded conductors.

# 18.

## ***Antenna Safety***

### **18.1 Erecting Antennas on Masts**

Erecting antennas pose some danger especially if they encounter power lines. Never erect an antenna near a power line. Make sure to leave enough clearance so if the antenna supporting structures fall they will clear the power lines. There are many cases of metal masts being raised accidentally encountering power lines, electrocuting the person or persons raising the masts. To raise a mast can expose you to a large force called leverage, which appears to increase the weight of the mast. Exerting oneself to raise a heavy mast can result in painful muscle and back injuries. Never try to raise a mast without sufficient help.

### **18.2 Tower Safety**

A tower is a wonderful device for supporting wire and beam antennas, but a person who has never put up one should seek advice of people who have experience in erecting towers. The obvious danger is falling off the tower. It should never be climbed without a climbing belt. Most people falling off a tower do so because of some kind of equipment failure or the tower collapses because of overload.

In erecting a tower, a gin pole strong enough to support the weight of the tower section being raised should be used. Do not use improvised gin poles, as the strength of them may not support the weight of the tower section and the force from the other end of the rope being pulled by the ground crew. To hold a 50-pound tower section stationary requires a hundred pounds of force, which is the weight of the tower section and 50 pounds of force of the ground crew. The ground crew must exert more than 50 pounds of force to cause the section to be raised. There would be no greater tragedy than the gin pole breaking dropping the tower section on the ground crew. Then there is the possibility of the person on the tower being knocked loose by the falling, broken gin pole.

Another problem can arise if under-sized guy cables and clamps are used to support the tower. We have seen tower failure when guy cables broke in a windstorm, or an insufficient number of clamps holding the guy cable allowed the cable to pull through the clamps. Professional



tower people do not use cable clamps. They use “preformed tie-wraps” that grip the guy cables tighter as the force in the guy cables increases. Preformed tie-wraps are available from Texas Towers. Never tie the ground end of a guy cable to a tree. A tree swaying in a heavy windstorm can put enough force on the cable to cause it to break or to pull the tower over. Screw-in anchors available from mobile home suppliers make adequate anchors. Do not anchor a guy cable where a tree can fall across the guy cable. This could break the guy cable and cause the tower to fall. Never place a tower near a house, where if it falls, it could hit the house. Remember *Safety First!*

These lengths are for coax having a solid dielectric with a velocity factor of 0.66 and foam dielectric with a velocity factor of 0.78. , You can use odd multiples like 3, 5, 7, etc. of the lengths below if those lengths are too short for your installation

**Table 18.1: Quarter Wave Matching Sections of 70-ohm Coax**

		Foam dielectric cable
160 meters	85ft 6in	106ft 4in
80 Meters	43ft 4in	51ft 9 in
40 Meters	22ft 6in	27ft 6 in
30 Meters	16ft 0in	19ft 6 in
20 Meters	11ft 5in	13ft 10 in
17 Meters	8ft 11 in	10ft 9 in
15 Meters	7ft 7 in	8ft 4 in
12 Meters	6ft 6in	8 ft 0in
10 Meters	5ft 8 3/8 in	6ft 11 in

Questions? Email Jim Abercrombie [n4ja@prtcnet.com](mailto:n4ja@prtcnet.com).

Hamuniverse.com is Powered by Ham Radio!

© 2000 - 2008 N4UJW Hamuniverse.com or article author! - All Rights Reserved.